

- 3. CIRCUIT BLOCK DIAGRAM
 - 3.1 Electrical Block Diagram
 - 3.2 Pins Definition
 - 3.3 Power Supply For LCM Driving
- 4. ABSOLUTE MAXIMUM RATINGS
 - 4.1 Electrical Absolute Maximum Ratings
 - 4.2 Environmental Absolute Maximum Ratings
- 5. ELECTRICAL CHARACTERISTICS
 - 5.1 DC Characteristics
 - 5.2 MPU Interface AC Characteristics
- 6. BACKLIGHT CHARACTERISTICS
- 7. ELECTRO-OPTICAL CHARACTERISTIC
- 8. INSPECTION STANDARDS
- 9. PRECAUTIONS IN USING LCM

1. LCD MODULE NUMBERING SYSTEM

PART NUMBER: PL-AB...BC-DEFGHI-JK

PL POWER LIGHT TECHNOLOGY
A DISPLAY CONTENTS S---SEGMENT TYPE
 C---CHARACTER TYPE
 G---GRAPHIC TYPE
B...B SERIALS NUMBER FOR SM
 CHARACTERS Vs. LINES FOR CM

POWER LIGHT

C COLUMNS Vs. ROWS FOR GM
D VERSION OF PCB
 LCD TYPE
 P---POS. TN, N---NEG. TN, Y---YELLOW STN, G---GRAY STN
 B---BLUE STN, F---FSTN
E POLARIZER TYPE
 R---REFLECTIVE, F---TRANSFLECTIVE, T---TRANSMISSIVE
F VIEWING ANGLE S---6 O'CLOCK, T---12 O'CLOCK
G OPERATING TEMPRETURE N---NORMAL, E---EXTENDED
H BACKLIGHT TYPE N---NO BACKLIGHT, D---BOTTOM LED, S---SIDE LED,
 E---EL, C---CCFL
I COLOR OF BACKLIGHT Y---YELLOW/GREEN, G---GREEN
 W---WHITE, B---BLUE, A---AMBER
JK FOR CM, CONTROLLER/DRIVER DESIGNATOR
 J: IC A---KS0066U B---SPLC780
 K: DENOTE DIFFERENT CHARACTER TABLE
 FOR GM. J: BACKLIGHT DRIVER Y---WITH, N---WITHOUT
 K: DC-DC CONVERTER Y---WITH, N---WITHOUT

2. MECHANICAL CHARACTERISTICS

2.1 MECHANICAL DATA

ITEM	STANDARD VALUE	UNIT
NUMBER OF PIXELS	320(COLUMNS) X 240(ROWS)	
OUTLINE DIMENSIONS	143.0(W) X 96.8(H) X 12.0(T)	mm
EFFECTTVE VIEWING AREA	104.0(W) X 79.3(H)	mm
DOT SIZE	0.37(W) X 0.40(H)	mm
DOT PITCH	0.40(W) X 0.43(H)	mm
APPROX WEIGHT	120(LED BL VERSION)	g

2.2 MECHANICAL DRAWINGS

POWER LIGHT

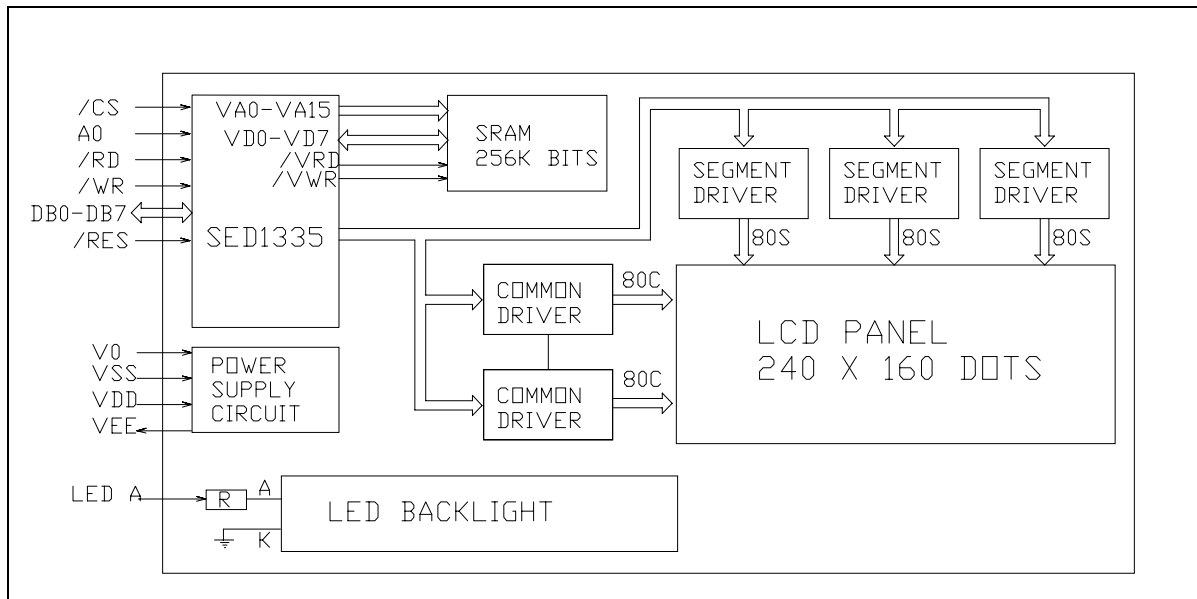

3.2 Pins Definition

3.2.1 For types without controller SED1335

CN1 and CN3

PIN	SYMBOL	FUNCTION
1	FRAME	Frame Signal
2	M	AC Signal For LCD Driver Output
3	CL1	Data Latch Clock
4	CL2	Data Shift Clock
5	/DISPOFF	Display Off Control
6-9	D0-D3	Display Data Input
10	VDD	Power supply
11	VSS	GND
12	VEE	Negative Voltage Input/Output
13	V0	Display Contrast Adjust
14	FG	Bezel Ground

3.2.2 For types with controller SED1335

CN2 and CN4

PIN	SYMBOL	FUNCTION

1	VSS	GND
2	VDD	Power Supply(+5V)
3	V0	Display Contrast Adjust
4	/WR	Write Signal
5	/RD	Read Signal
6	/CS	Chip Select
7	A0	Data Type Select While Write----1: Command Write 0: Data Write While Read----1: Status Read 0:Data Read
8	/RES	Reset
9-16	DB0—DB7	Data Bus
17	ELC	Backlight ON/OFF Control
18	VEE	Negative Voltage Input/Output

3.3 Power Supply For LCM Driving

3.3.1 For LCM With DC/DC on Board(Internal Negative Voltage)

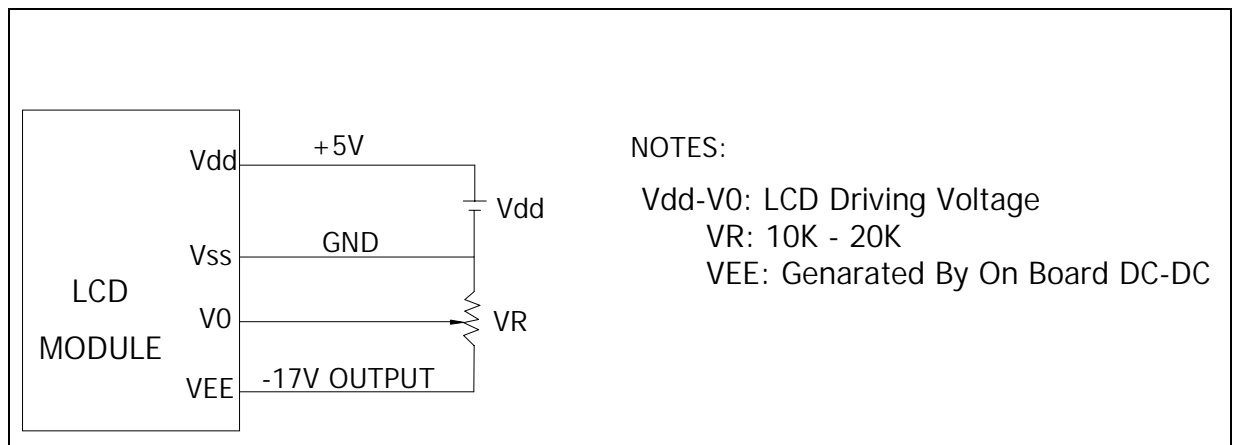

3.3.2 For LCM without DC/DC on Board(Negative Voltage input)

POWER LIGHT

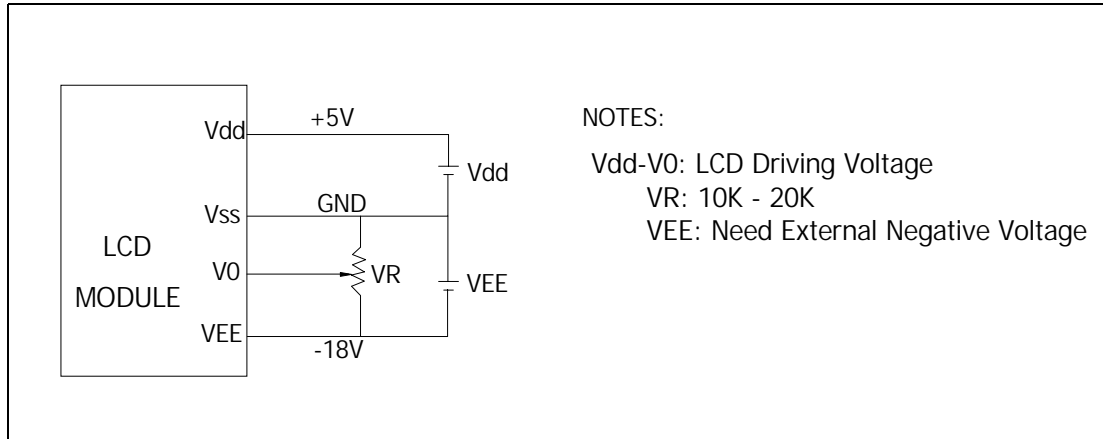

4. ABSOLUTE MAXIMUM RATINGS

4.1 Electrical Absolute Maximum Ratings

ITEM	SYMBOL	CONDITION	MIN	MAX	UNIT
Operating Voltage	Vdd – Vss	-	-0.3	7.0	V
Supply Voltage	Vee-Vss	-	Vdd-30.0	Vdd+0.3	V
Supply Voltage	V0-Vss	-	Vee-0.3	Vdd+0.3	V
Input Voltage	Vi	-	-0.3	Vdd +0.3	V

4.2 Environmental Absolute Maximum Ratings

ITEM	SYMBOL	CONDITIONS	MIN	MAX	UNIT
Operating Temp	Topr	-Normal temp.	0	50	deg C
Storage Temp	Ttsg	version-	-20	70	deg C
Operating Temp	Topr	Extended temp.	-20	70	deg C
Storage Temp	Ttsg	version	-30	80	deg C
Humidity Endurance	RH	no ondensation Ta <= 40 deg	-	95	%
Vibration	-	100-300Hz, X/Y/Z directions, 1 hour	-	4.9m/ss 0.5g	-
Shock	-	10 mS X/Y/Z direction 1 time each	-	29.4m/ss 3.0g	-

5. ELECTRICAL CHARACTERISTICS

5.1 DC Characteristics

POWER LIGHT

Electrical Characteristics at Ta=25 deg C, Vdd = 5V + / - 5%

For models with SED1335 and DC/DC on board

ITEM	SYMBOL	CONDITION	MIN	TYP	MAX	UNIT
Supply Voltage (logic)	Vdd-Vss	-	4.5	5.0	5.5	V
Supply Voltage (LCD)	Vdd-V0	Vdd = 5V	-	17.5	-	V
Input Signal Voltage	V-ih	"H" level	Vdd-2.2	-	Vdd	V
	V-il	"L" level	0	-	0.8	V
Output Signal Voltage	V-oh	"H" level	Vdd-0.3	-	Vdd	V
	V-ol	"L" level	0	-	0.3	V
Supply Current (logic+LCD)	Idd	Vdd=5.0V	-	75	-	mA
Supply Current (LCD)	Io	Vdd-V0=17.5V	-	5.0	-	mA

5.2 MPU Interface AC Characteristics

Test Conditions: Ta = -20 to 75°C, Vdd = 5V+/-10%, Vss =0V

ITEM	SYMBOL	MIN	MAX	UNIT
Address Hold Time	t _{AH8}	10	-	ns
Address Setup Time	t _{AW8}	30	-	ns
Strobe Pulsewidth	t _{CC}	220	-	ns
Data Set-up Time	t _{DS8}	120	-	ns
Data Hold Time	t _{DH8}	10	-	ns
RD Access Time	t _{ACC}	-	120	ns
Output Hold Time	t _{OH8}	10	50	ns

BUS TIMING

POWER LIGHT

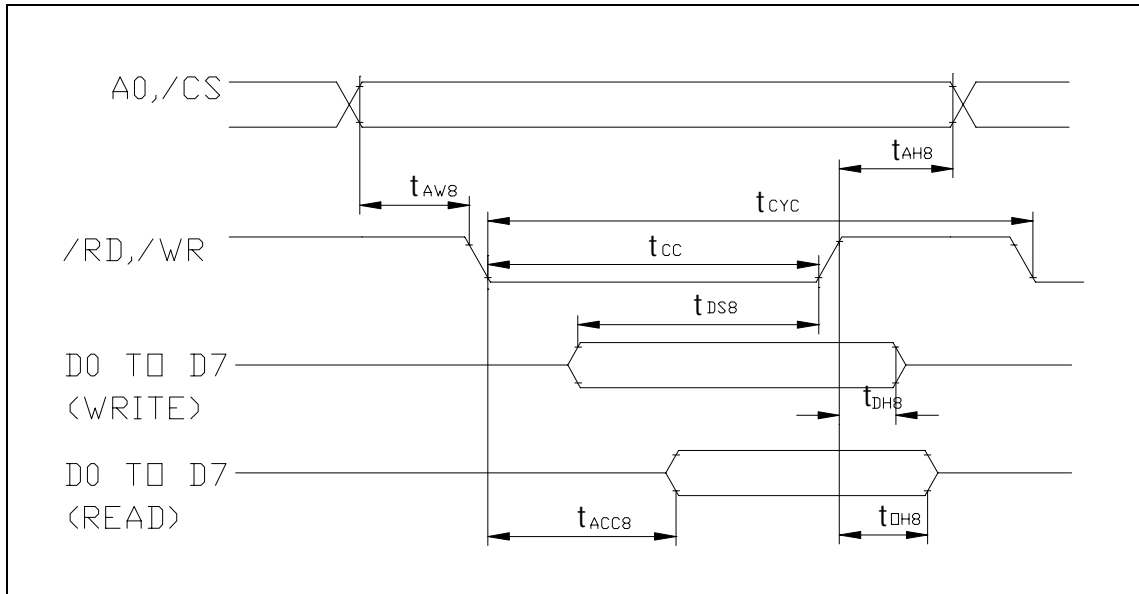

6. BACKLIGHT CHARACTERISTICS

For Side-Lit LED Backlight ($T_a=25^\circ\text{C}$), color: white

ITEM	SYMBOL	CONDITION	MIN.	TYP.	MAX.	UNIT
Forward Voltage	V_f		-	3.0	3.2	V
Forward Current	I_f	-	-	200	-	mA
Reverse Voltage	V_r	-	-	-	8	V
Peak Wave Length	λ_p	-		White		
Power Dissipation	P_d	-	-	700	-	mW

7. ELECTRO-OPTICAL CHARACTERISTICS

ITEM	SYMBOL	CONDITION	MIN.	TYP.	MAX.	UNIT	REF.
------	--------	-----------	------	------	------	------	------

Contrast	CR	25°C	4	--	--		Note1
Rise Time	tr	25°C	--	160	240	ms	Note2
Fall Time	tf	25°C	--	100	150	ms	note 2
Viewing Angle	$\theta 1 - \theta 2$	25°C	--	--	60	DEG	Note 3
	$\emptyset 1, \emptyset 2$		-40(S)/-15(T)	--	40		
Frame Frequency	Ff	25°C	--	70	--	Hz	note 2

Note(1): Contrast ratio is defined under the following condition:

CR= $\frac{\text{brightness of selected condition}}{\text{brightness of non-selected condition}}$

- (a). Temperature-----25C
- (b). Frame Frequency-----64Hz
- (c). Viewing angle----- $\theta = 0, \emptyset = 0$
- (d). Operating Voltage---5.0V

Note(2): definition of response time:

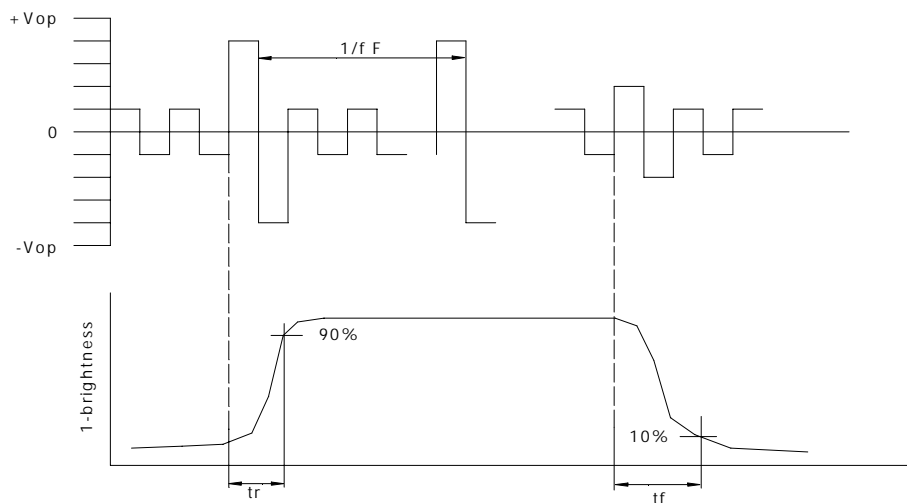

Condition:

- (a). Temperature-----25C
- (b). Frame Frequency-----64Hz
- (c). Viewing angle----- $\theta = 0, \emptyset = 0$
- (d). Operating Voltage---5.0V

Note(3): definition of view angle:

POWER LIGHT

TOP-BOTTOM DIRECTION

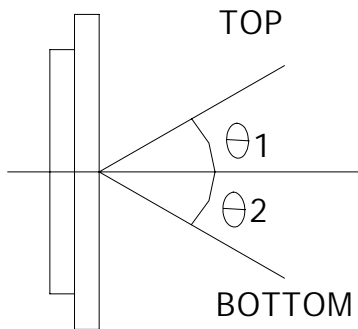

RIGHT-LEFT DIRECTION

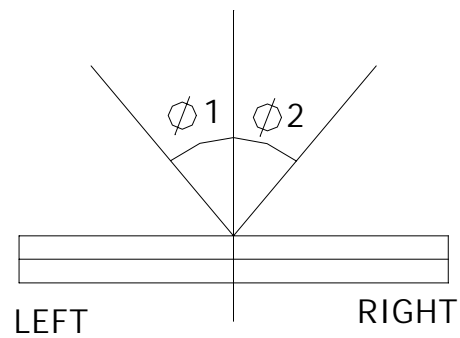

8. INSPECTION STANDARDS

8.1 Inspection Conditions

The LCD shall be inspected under 40W white fluorescent light.

The distance between the eyes and the samples shall be more than 30cm.

All directions for inspecting the sample should be within 45 degree against perpendicular line.

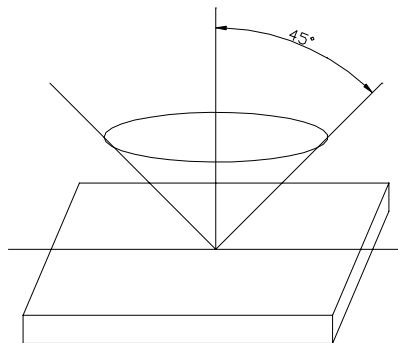

8.2 Definition of Applicable Zone

POWER LIGHT

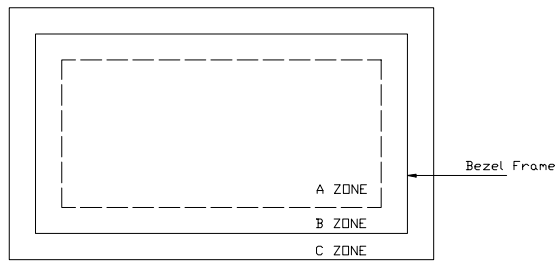

A Zone: Active Display Area
 B Zone: Area from Bezel Frame to A Zone
 C Zone: Rest Area of Bezel
 A Zone + B Zone=Effective Viewing Area

8.3 Standards

NO	PARAMETER	CRITERIA																																																										
1	Black and White Spots, Foreign Substances	<p>Round Shape</p> <table border="1"> <thead> <tr> <th rowspan="2">Zone</th> <th colspan="3">Acceptable Number</th> </tr> <tr> <th>A</th> <th>B</th> <th>C</th> </tr> </thead> <tbody> <tr> <td>DIMENSION(MM)</td> <td></td> <td></td> <td></td> </tr> <tr> <td>$D \leq 0.1$</td> <td>*</td> <td>*</td> <td>*</td> </tr> <tr> <td>$0.1 < D \leq 0.2$</td> <td>5</td> <td>5</td> <td>*</td> </tr> <tr> <td>$0.2 < D \leq 0.3$</td> <td>0</td> <td>1</td> <td>*</td> </tr> <tr> <td>$0.3 < D$</td> <td>0</td> <td>0</td> <td>*</td> </tr> </tbody> </table> <p>$D = (\text{long} + \text{short}) / 2$ * Disregard</p> <p>Line Shape</p> <table border="1"> <thead> <tr> <th rowspan="2">Zone</th> <th colspan="3">Acceptable Number</th> </tr> <tr> <th>A</th> <th>B</th> <th>C</th> </tr> </thead> <tbody> <tr> <td>X(mm) Y(mm)</td> <td></td> <td></td> <td></td> </tr> <tr> <td>- $0.02 \geq W$</td> <td>*</td> <td>*</td> <td>*</td> </tr> <tr> <td>$2.0 \geq L$ $0.03 \geq W$</td> <td>3</td> <td>3</td> <td>*</td> </tr> <tr> <td>$1.0 \geq L$ $0.04 \geq W$</td> <td>1</td> <td>2</td> <td>*</td> </tr> <tr> <td>$1.0 \geq L$ $0.05 \geq W$</td> <td>0</td> <td>2</td> <td>*</td> </tr> <tr> <td>- $0.05 < W$</td> <td colspan="3">Not acceptable</td> </tr> </tbody> </table> <p>X: Length Y: Width * Disregard</p> <p>Total defects shall not exceed 5.</p>	Zone	Acceptable Number			A	B	C	DIMENSION(MM)				$D \leq 0.1$	*	*	*	$0.1 < D \leq 0.2$	5	5	*	$0.2 < D \leq 0.3$	0	1	*	$0.3 < D$	0	0	*	Zone	Acceptable Number			A	B	C	X(mm) Y(mm)				- $0.02 \geq W$	*	*	*	$2.0 \geq L$ $0.03 \geq W$	3	3	*	$1.0 \geq L$ $0.04 \geq W$	1	2	*	$1.0 \geq L$ $0.05 \geq W$	0	2	*	- $0.05 < W$	Not acceptable		
Zone	Acceptable Number																																																											
	A	B	C																																																									
DIMENSION(MM)																																																												
$D \leq 0.1$	*	*	*																																																									
$0.1 < D \leq 0.2$	5	5	*																																																									
$0.2 < D \leq 0.3$	0	1	*																																																									
$0.3 < D$	0	0	*																																																									
Zone	Acceptable Number																																																											
	A	B	C																																																									
X(mm) Y(mm)																																																												
- $0.02 \geq W$	*	*	*																																																									
$2.0 \geq L$ $0.03 \geq W$	3	3	*																																																									
$1.0 \geq L$ $0.04 \geq W$	1	2	*																																																									
$1.0 \geq L$ $0.05 \geq W$	0	2	*																																																									
- $0.05 < W$	Not acceptable																																																											

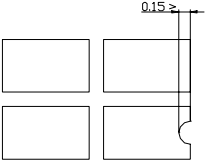
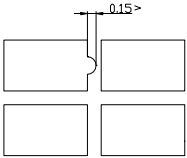
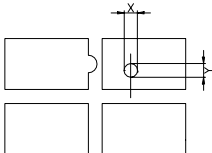
		Zone			
		Dimension(mm)	A	B	C
2	Air Bubbles (Between glass and polarizer)	$D \leq 0.1$	*	*	*
		$0.1 < D \leq 0.2$	5	5	*
		$0.2 < D \leq 0.3$	0	1	*
		$0.3 < D$	0	0	*
		*: Disregard Total defects shall not exceed 3.			
3	The Shape of Dot	(1) Dot Shape(with dent)			
		 <p>As per the sketch of left hand.</p>			
		(2) Dot Shape(with Projection)			
		 <p>Should not connect to next dot.</p>			
		(3) Pin Hole			
		 <p>$(X+Y)/2 < 0.2\text{mm}$ (less than 0.1mm is not counted)</p>			
		Total defects shall not exceed 5.			
4	Polarizer Scratches	Not to be conspicuous defects.			
5	Polarizer Dirts	If the stains are removed easily from LCD surface, the module is not defective.			
6	Color Variation	Not to be conspicuous defects.			

9. PRECAUTIONS IN USING LCM

1. LIQUID CRYSTAL DISPLAY (LCD)

LCD is made up of glass, organic sealant, organic fluid, and polymer based polarizers. The

following precautions should be taken when handling,

- (1). Keep the temperature within range of use and storage. Excessive temperature and humidity could cause polarization degradation, polarizer peel off or bubble.
- (2). Do not contact the exposed polarizers with anything harder than an HB pencil lead. To clean dust off the display surface. Wipe gently with cotton. Chamois or other soft material soaked in petroleum benzine.
- (3). Wipe off saliva or water drops immediately. Contact with water over a long period of time may cause polarizer deformation or color fading, while an active LCD with water condensation on its surface will cause corrosion of ITO electrodes.
- (4). Glass can be easily chipped or cracked from rough handling, especially at corners and edges.
- (5). Do not drive LCD with DC voltage.

2. Liquid Crystal Display Modules

2.1 Mechanical Considerations

LCM are assembled and adjusted with a high degree of precision. Avoid excessive shocks and do not make any alterations or modifications. The following should be noted.

- (1). Do not tamper in any way with the tabs on the metal frame.
- (2). Do not modify the PCB by drilling extra holes, changing its outline, moving its components or modifying its pattern.
- (3). Do not touch the elastomer connector, especially insert a backlight panel (for example, EL).
- (4). When mounting a LCM make sure that the PCB is not under any stress such as bending or twisting. Elastomer contacts are very delicate and missing pixels could result from slight dislocation of any of the elements.
- (5). Avoid pressing on the metal bezel, otherwise the elastomer connector could be deformed and lose contact, resulting in missing pixels.

2.2. Static Electricity

LCM contains CMOS LSI's and the same precaution for such devices should apply, namely

- (1). The operator should be grounded whenever he/she comes into contact with the module. Never touch any of the conductive parts such as the LSI pads, the copper leads on the PCB and the interface terminals with any parts of the human body.
- (2). The modules should be kept in antistatic bags or other containers resistant to static for storage.
- (3). Only properly grounded soldering irons should be used.
- (4). If an electric screwdriver is used, it should be well grounded and shielded from commutator sparks.
- (5). The normal static prevention measures should be observed for work clothes and working benches; for the latter a conductive (rubber) mat is recommended.
- (6). Since dry air is inductive to statics, a relative humidity of 50-60% is recommended.

2.3. Soldering

- (1). Solder only to the I/O terminals.
- (2). Use only soldering irons with proper grounding and no leakage.
- (3). Soldering temperature: $280\text{ }^{\circ}\text{C} \pm 10^{\circ}\text{C}$
- (4). Soldering time: 3 to 4 sec.
- (5). Use eutectic solder with resin flux fill.
- (6). If flux is used, the LCD surface should be covered to avoid flux spatters. Flux residue should be removed afterwards.

2.4. Operation

- (1). The viewing angle can be adjusted by varying the LCD driving voltage V_0 .

- (2). Driving voltage should be kept within specified range; excess voltage shortens display life.
- (3). Response time increases with decrease in temperature.
- (4). Display may turn black or dark blue at temperatures above its operational range; this is (however not pressing on the viewing area) may cause the segments to appear "fractured".
- (5). Mechanical disturbance during operation (such as pressing on the viewing area) may cause the segments to appear "fractured".

2.5. Storage

If any fluid leaks out of a damaged glass cell, wash off any human part that comes into contact with soap and water. Never swallow the fluid. The toxicity is extremely low but caution should be exercised at all the time.

THE END

POWER LIGHT