



- 3.1 Electrical Block Diagram
- 3.2 Pins Definition
- 3.3 Power Supply For LCM Driving
- 4. ABSOLUTE MAXIMUM RATINGS
  - 4.1 Electrical Absolute Maximum Ratings
  - 4.2 Environmental Absolute Maximum Ratings
- 5. ELECTRICAL CHARACTERISTICS
  - 5.1 DC Characteristics
  - 5.2 MPU Interface AC Characteristics
- 6. BACKLIGHT CHARACTERISTICS
- 7. ELECTRO-OPTICAL CHARACTERISTIC
- 8. DISPLAY CONTROL INSTRUCTION
  - 8.1 INSTRUCTION TABLE
  - 8.2 Explanation Of The Instructions
  - 8.3 Reset Operation
  - 8.4 Busy Flag Explanation
  - 8.5 Display Data RAM Map
- 9. INSPECTION STANDARDS
- 10. PRECAUTIONS IN USING LCM

## 1. LCD MODULE NUMBERING SYSTEM

**PART NUMBER: PL-AB...BC-DEFGHI-JK**

**PL** POWER LIGHT TECHNOLOGY  
**A** DISPLAY CONTENTS S---SEGMENT TYPE  
 C---CHARACTER TYPE  
 G---GRAPHIC TYPE  
**B...B** SERIALS NUMBER FOR SM  
 CHARACTERS Vs. LINES FOR CM  
 COLUMNS Vs. ROWS FOR GM  
**C** VERSION OF PCB  
**D** LCD TYPE  
 P---POS. TN, N---NEG. TN, Y---YELLOW STN, G---GRAY STN

POWER LIGHT

**E** B---BLUE STN, F---FSTN  
 POLARIZER TYPE  
 R---REFLECTIVE, F---TRANSFLECTIVE, T---TRANSMISSIVE  
**F** VIEWING ANGLE S---6 O'CLOCK, T---12 O'CLOCK  
**G** OPERATING TEMPRETURE N---NORMAL, E---EXTENDED  
**H** BACKLIGHT TYPE N---NO BACKLIGHT, D---BOTTOM LED, S---SIDE LED,  
 E---EL, C---CCFL  
**I** COLOR OF BACKLIGHT Y---YELLOW/GREEN, G---GREEN  
 W---WHITE, B---BLUE, A---AMBER  
**JK** FOR CM, CONTROLLER/DRIVER DESIGNATOR  
 J: IC A---KS0066U B---SPLC780  
 K: DENOTE DIFFERENT CHARACTER TABLE  
 FOR GM. J: BACKLIGHT DRIVER Y---WITH, N---WITHOUT  
 K: DC-DC CONVERTER Y---WITH, N---WITHOUT

## 2. MECHANICAL CHARACTERISTICS

### 2.1 MECHANICAL DATA

ITEM	STANDARD VALUE	UNIT
NUMBER OF PIXELS	128(COLUMNS) X 64(ROWS)	
OUTLINE DIMENSIONS	93.0(W) X 70.0(H) X 14.0/10.0(T)	mm
EFFECTTVE VIEWING AREA	72.0(W) X 40.0(H)	mm
DOT SIZE	0.48(W) X 0.48(H)	mm
DOT PITCH	0.52(W) X 0.52(H)	mm
APPROX WEIGHT	60(LED BL VERSION)/45(NO BL)	g

### 2.2 MECHANICAL DRAWINGS

POWER LIGHT

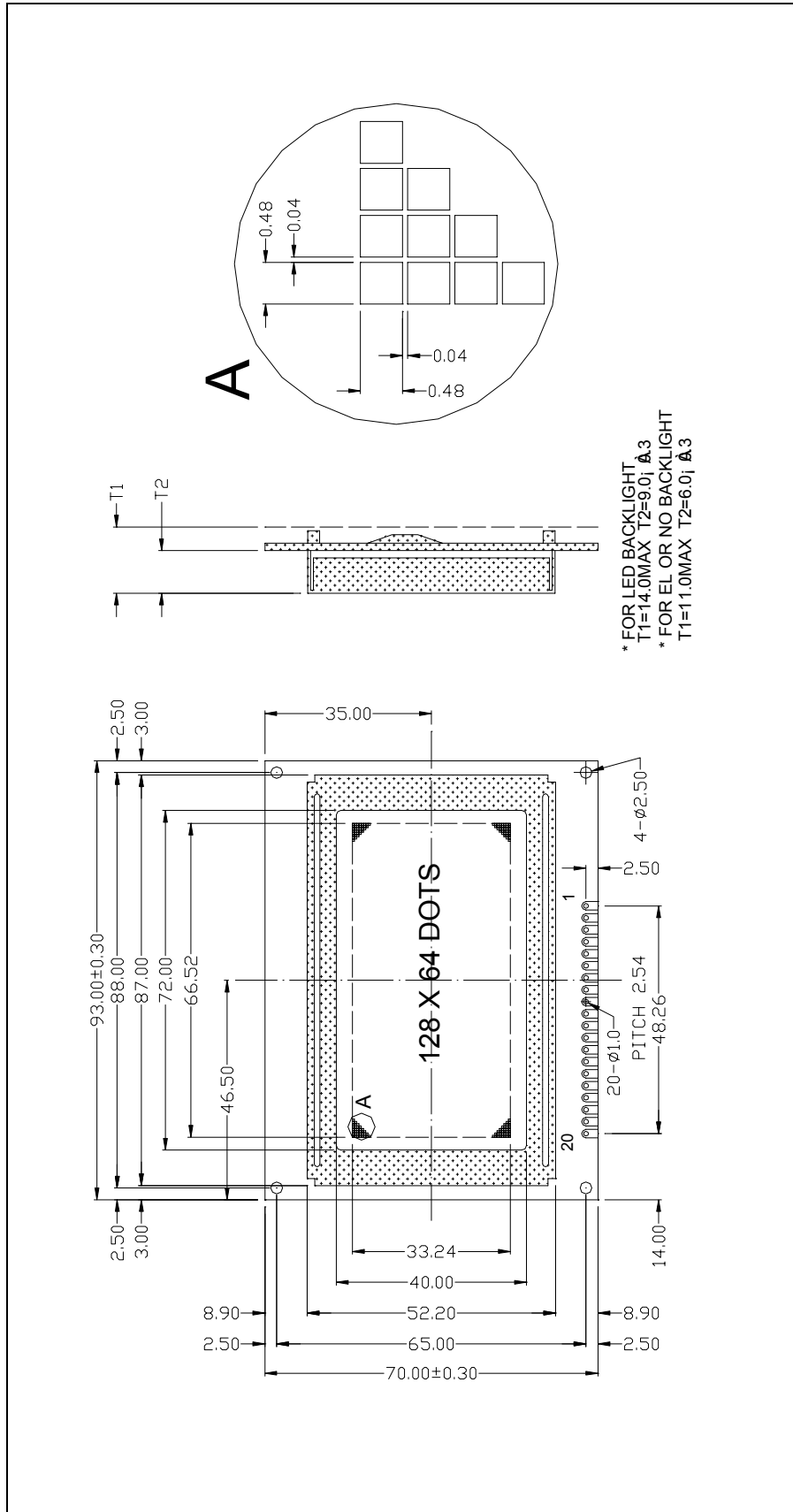

### 3. CIRCUIT BLOCK DIAGRAM

#### 3.1 Electrical Block Diagram

POWER LIGHT

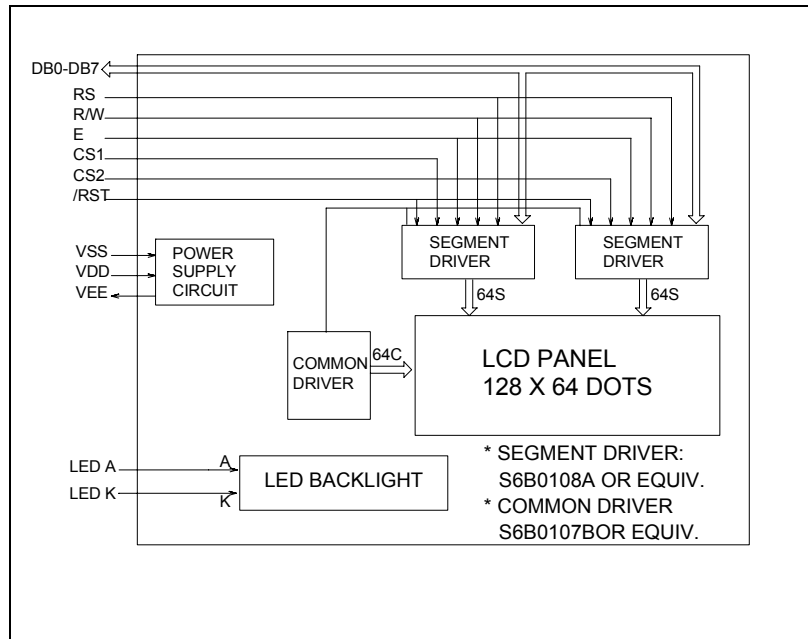

### 3.2 Pins Definition

PIN	SYMBOL	FUNCTION
1	Vss	Power Supply(GND)
2	Vdd	Power Supply(+5V)
3	Vo	Contrast Adjust
4	RS	Data/Instruction Select H: Display Data; L: Instruction Code
5	R/W	Read/Write Select H: Read(LCM to uC); L: Write(uC to LCM)
6	E	Enable Signal Read Data When E is High; Write Data At The Falling Edge of E
7-14	DB0-DB7	Data Bus: 3-States I/O Terminal
15	CS1	Chip Selection for IC1, Active High
16	CS2	Chip Selection for IC2, Active High
17	/RST	Reset Signal, Active Low
18	VEE	Negative Voltage Output/Input (-10V)
19	A	Power Supply for LED B/L(+)
20	K	Power Supply for LED B/L(-)

### 3.3 Power Supply For LCM Driving

#### 3.3.1 For LCM With DC/DC on Board(Internal Negative Voltage)

POWER LIGHT

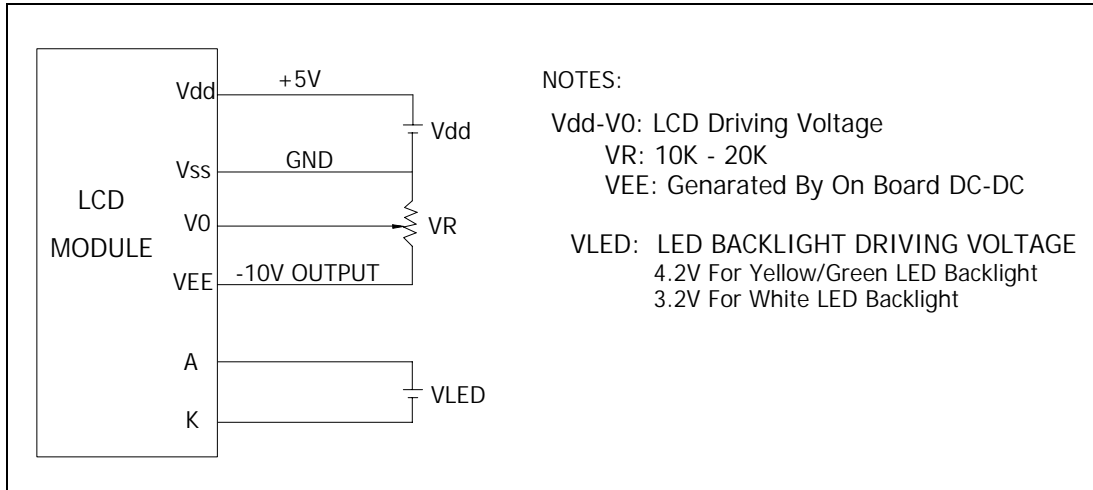

### 3.3.2 For LCM without DC/DC on Board(Negative Voltage input)

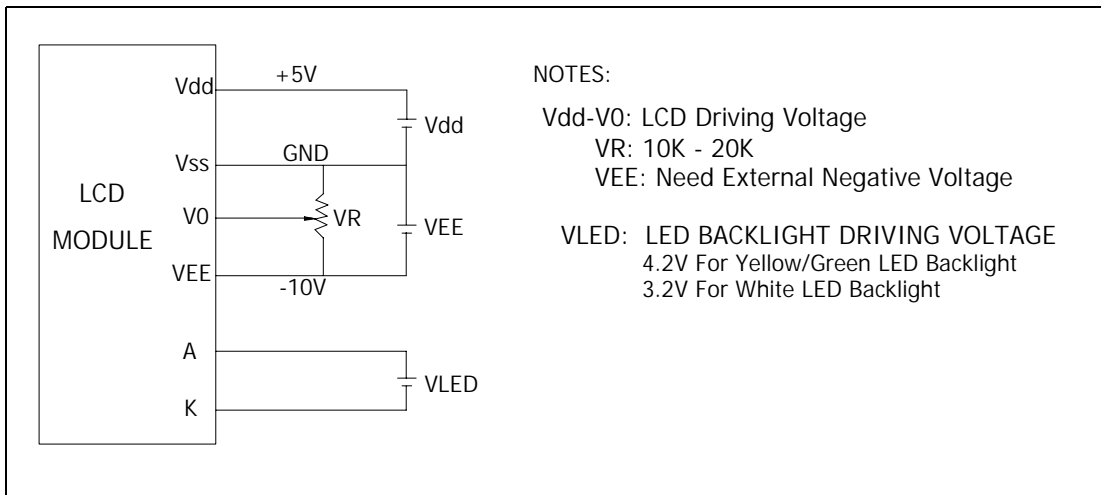

## 4. ABSOLUTE MAXIMUM RATINGS

### 4.1 Electrical Absolute Maximum Ratings

ITEM	SYMBOL	CONDITION	MIN	MAX	UNIT
Operating Voltage	Vdd – Vss	-	-0.3	7.0	V
Supply Voltage	Vee-Vss	-	Vdd-19.0	Vdd+0.3	V
Supply Voltage	V0-Vss	-	Vee-0.3	Vdd+0.3	V
Input Voltage	Vi	-	-0.3	Vdd +0.3	V

### 4.2 Enviromental Absolute Maximum Ratings

ITEM	SYMBOL	CONDITIONS	MIN	MAX	UNIT
Operating Temp	Topr	-Normal temp.	0	50	deg C
Storage Temp	Ttsg	version-	-20	70	deg C

Operating Temp	Topr	Extended temp. version	-20	70	deg C
Storage Temp	Ttsg		-30	80	deg C
Humidity Endurance	RH	no ondensation Ta<=40 deg	-	95	%
Vibration	-	100-300Hz, X/Y/Z directions, 1 hour	-	4.9m/ss 0.5g	-
Shock	-	10 mS X/Y/Z direction 1 time each	-	29.4m/ss 3.0g	-

## 5. ELECTRICAL CHARACTERISTICS

### 5.1 DC Characteristics

Electrical Characteristics at Ta=25 deg C, Vdd = 5V + / - 5%

ITEM	SYMBOL	CONDITION	MIN	TYP	MAX	UNIT
Supply Voltage (logic)	Vdd-Vss	-	4.5	5.0	5.5	V
Supply Voltage (LCD)	Vdd-V0	Vdd = 5V	-	14.2	-	V
Input Signal Voltage	V-ih	"H" level	2.0	-	Vdd	V
	V-il	"L" level	0	-	0.8	V
Output Signal Voltage	V-oh	"H" level	2.4	-	-	V
	V-ol	"L" level	-	-	0.4	V
Supply Current (logic)	Idd	-	-	6.0	8.0	mA
Supply Current (LCD)	Io	-	-	0.3	0.4	mA

### 5.2 MPU Interface AC Characteristics

TIMING SPECIFICATIONS at Ta = 25 deg C, Vdd = 5V+/-10%, Vss =0V

ITEM	SYMBOL	MIN	MAX	UNIT
E Cycle	tc	1000	-	ns
E High Level Width	tWH	450	-	ns
E Low Level Width	tWL	450	-	ns

E Rise Time	$t_R$	-	25	ns
E Fall Time	$t_F$	-	25	ns
Address Setup Time	$t_{ASU}$	140	-	ns
Address Hold Time	$t_{AH}$	10	-	ns
Data Setup Time	$t_{DSU}$	200		ns
Data Delay Time	$t_D$	-	320	ns
Data Hold Time(Write)	$t_{DHW}$	10		ns
Data hold time(Read)	$t_{DHR}$	20	-	ns

### WRITE MODE TIMING DIAGRAM

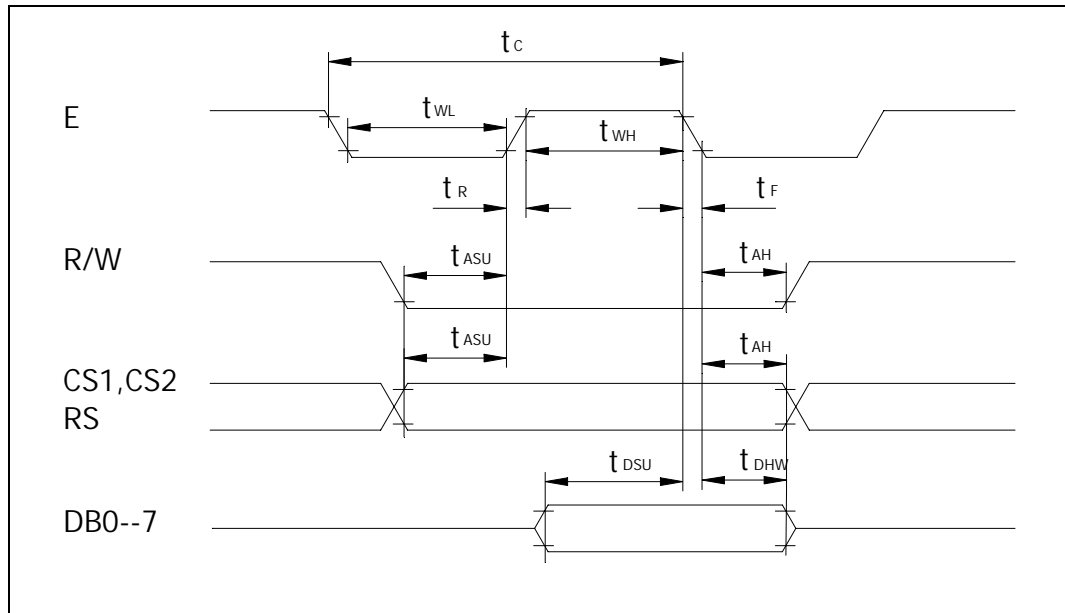

### READ MODE TIMING DIAGRAM

POWER LIGHT

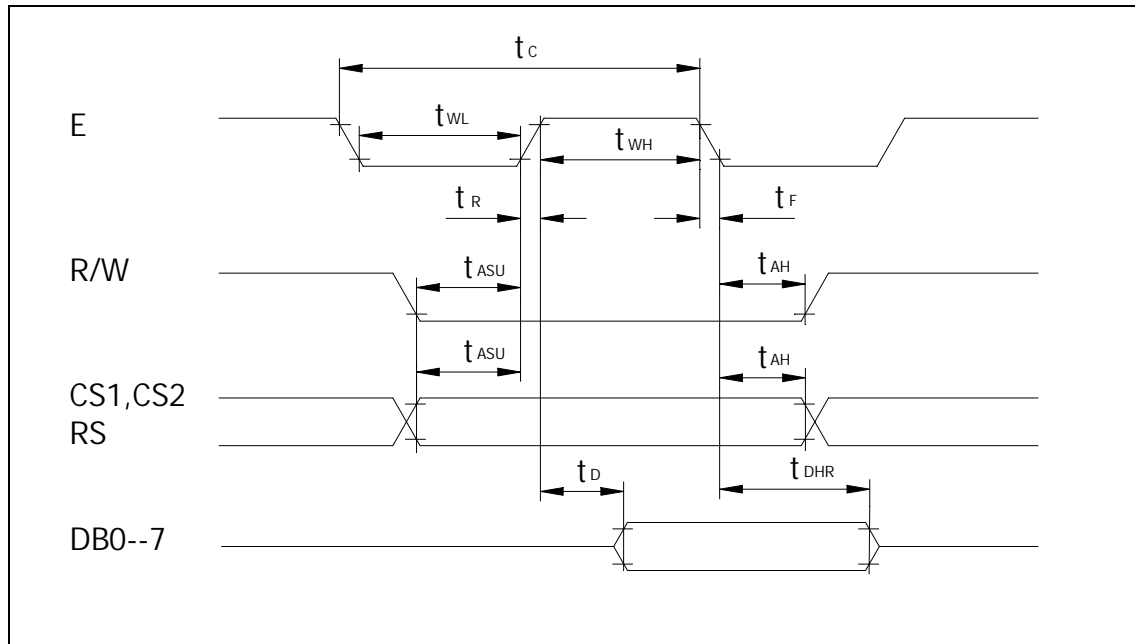

## 6. BACKLIGHT CHARACTERISTICS

For Bottom-Lit LED Backlight ( $T_a=25^\circ\text{C}$ )

ITEM	SYMBOL	CONDITION	MIN.	TYP.	MAX.	UNIT
Forward Voltage	$V_f$		-	4.2	4.6	V
Forward Current	$I_f$	$V_f=4.2\text{V}$	-	360	-	mA
Reverse Voltage	$V_r$	-	-	-	8	V
Peak Wave Length	$\lambda_p$	$V_f=4.2\text{V}$	-	568(Yellow/Green)	-	nm
Power Dissipation	$P_d$	$V_f=4.2\text{V}$	-	1550	-	mW

For Side-Lit LED Backlight ( $T_a=25^\circ\text{C}$ )

ITEM	SYMBOL	CONDITION	MIN.	TYP.	MAX.	UNIT
Forward Voltage	$V_f$		-	3.2	3.6	V
Forward Current	$I_f$	-	-	80	-	mA
Reverse Voltage	$V_r$	-	-	-	8	V
Peak Wave Length	$\lambda_p$	-		White		
Power Dissipation	$P_d$	-	-	256	-	mW

## 7. ELECTRO-OPTICAL CHARACTERISTICS

ITEM	SYMBOL	CONDITION	MIN.	TYP.	MAX.	UNIT	REF.
Contrast	CR	$25^\circ\text{C}$	4	--	--		Note1

Rise Time	tr	25°C	--	160	240	ms	Note2
Fall Time	tf	25°C	--	100	150	ms	note 2
Viewing Angle	$\theta 1 - \theta 2$	25°C	--	--	60	DEG	Note 3
	$\emptyset 1, \emptyset 2$		-40(S)/-15(T)	--	40		
Frame Frequency	Ff	25°C	--	70	--	Hz	note 2

Note(1): Contrast ratio is defined under the following condition:

CR=  $\frac{\text{brightness of selected condition}}{\text{brightness of non-selected condition}}$

- (a). Temperature-----25C
- (b). Frame Frequency-----64Hz
- (c). Viewing angle-----  $\theta = 0, \emptyset = 0$
- (d). Operating Voltage---5.0V

Note(2): definition of response time:

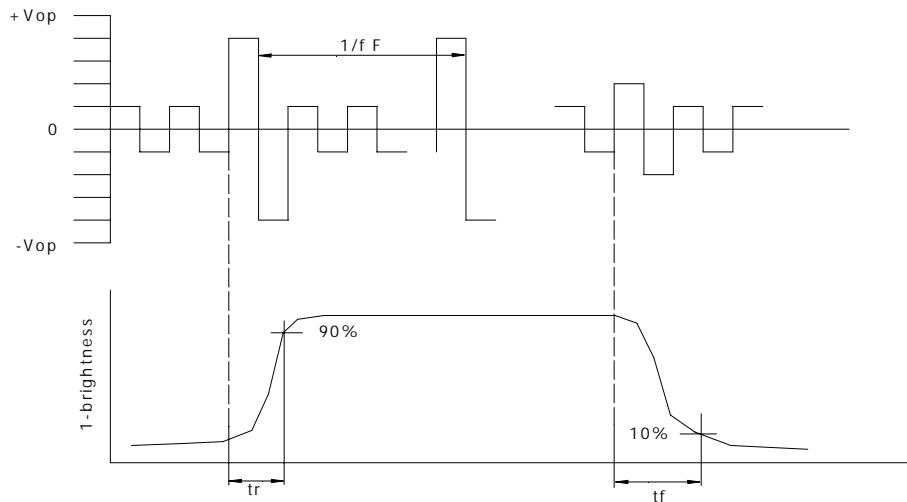

Condition:

- (a). Temperature-----25C
- (b). Frame Frequency-----64Hz
- (c). Viewing angle-----  $\theta = 0, \emptyset = 0$
- (d). Operating Voltage---5.0V

Note(3): definition of view angle:

POWER LIGHT

TOP-BOTTOM DIRECTION

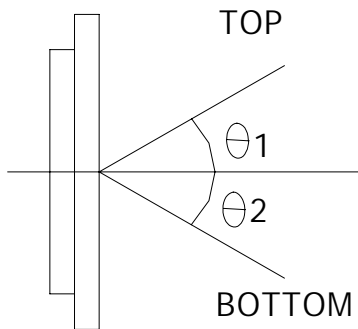

RIGHT-LEFT DIRECTION

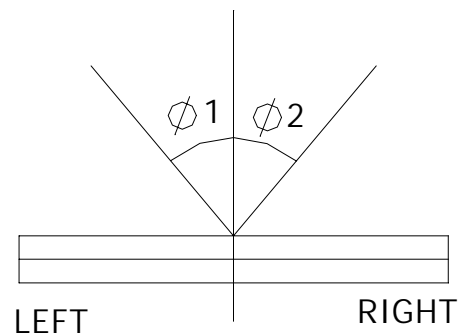

## 8. DISPLAY CONTROL INSTRUCTION

### 8.1 INSTRUCTION TABLE

Function	RS	R/W	DB 7	DB 6	DB 5	DB 4	DB 3	DB 2	DB 1	DB 0	Description
Display ON/OFF	0	0	0	0	1	1	1	1	1	0/1	Control the display on/off. Internal status and display RAM data is not affected. 0: OFF; 1: ON
Set Address (Y Address)	0	0	0	1	Y address(0—63)					Set the Y address in the Y address counter	
Set Page (X address)	0	0	1	0	1	1	1	Page(0—7)			Set the X address in the X address counter
Display Start line (Z Address)	0	0	1	1	Display Start Line(0—63)					Indicate the display data RAM displayed at the top of the screen	
Write Display Data	1	0	Display Data								Write data(DB0:7) into display data RAM. After writing, Y address is increased by 1 automatically.
Read Display Data	1	1	Display Data								Read data(DB0:7) from display data RAM to the data bus. After reading, Y address is increased by 1 automatically.
Status Read	0	1	B U S Y	0	O N/ O F F	R E S E T	0	0	0	0	Read Status Busy 0: Ready 1: In operation On/Off 0: Display On 1: Display Off Reset 0: Normal 1: Reset

### 8.2 Explanation Of The Instructions

#### 1. Display On/Off

RS	R/W	DB7	DB6	DB5	DB4	DB3	DB2	DB1	DB0
0	0	0	0	1	1	1	1	1	D

The display data appears when D is 1 and disappears when D is 0.

Though the display data is not on the screen when D is 0, it remains in the display data RAM. Therefore you can make it appear by changing D=0 to D=1.

2. Set Address (Y Address)

RS	R/W	DB7	DB6	DB5	DB4	DB3	DB2	DB1	DB0
0	0	0	1	AC5	AC4	AC3	AC2	AC1	AC0

Y address(AC0—AC5) of the display data RAM is set in the Y address counter.

An address is set by instruction and increased by 1 automatically by read or write operations of display data.

3. Set Page (X Address)

RS	R/W	DB7	DB6	DB5	DB4	DB3	DB2	DB1	DB0
0	0	1	0	1	1	1	AC2	AC1	AC0

X address(AC0—AC2) of the display data RAM is set in the X address register. Writing or reading to or from MPU is executed in this specified page until the next page is set.

4. Display Start Line(Z Address)

RS	R/W	DB7	DB6	DB5	DB4	DB3	DB2	DB1	DB0
0	0	1	1	AC5	AC4	AC3	AC2	AC1	AC0

Z address (AC0—AC5) of the display data RAM is set in the display start line register and displayed at the top of the screen. When the display duty cycle is 1/64 or others( 1/32—1/64), the data of total line number of LCD screen , from the line specified by display start line instruction, is displayed. It is used to scrolling the LCD screen.

5. Write Display Data

RS	R/W	DB7	DB6	DB5	DB4	DB3	DB2	DB1	DB0
0	1	D7	D6	D5	D4	D3	D2	D1	D0

Write data(D0—D7) into the display data RAM.

After writing, Y Address is increased by 1 automatically.

6. Read Display Data

RS	R/W	DB7	DB6	DB5	DB4	DB3	DB2	DB1	DB0
1	1	D7	D6	D5	D4	D3	D2	D1	D0

Read data(D0—D7) from the display data RAM.

After reading, Y Address is increased by 1 automatically.

7. Status Read

RS	R/W	DB7	DB6	DB5	DB4	DB3	DB2	DB1	DB0
0	1	BUSY	0	ON/OFF	RESET	0	0	0	0

**Busy** When busy is 1, the chip is executing internal operation and no instructions are accepted.

**ON/OFF** When ON/OFF is 1, the display is off  
When ON/OFF is 0, the display is on.

**Reset** When RESET is 1, the system is being initialized. In this condition, no instructions except status read can be accepted. When RESET is 0, initializing has finished and the system is in the normal operating condition.

### 8.3 Reset Operation

The system can be initialized by setting RSTB terminal at low level when turning power on, receiving instruction from MPU.

When RSTB becomes low, following procedure is occurred.

1. Display off
2. Display start line register become set by 0.(Z-address 0)

While RSTB is low, no instruction except status read can be accepted. Therefore, execute other instructions after making sure that DB4=0 and DB7=0 by status read instructions

Power supply initial conditions

Item	symbol	Min	Typ	Max	Unit
Reset Time	t <sub>RS</sub>	1.0	-	-	us
Rise Time	t <sub>R</sub>	-	-	200	ns

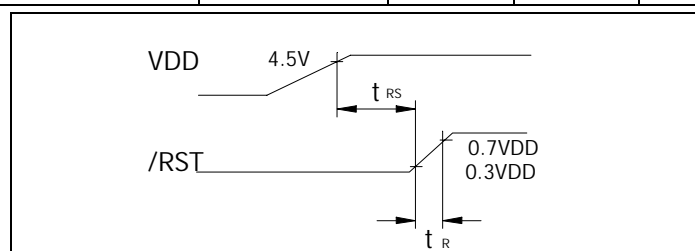

### 8.4 Busy Flag Explanation

Busy flag indicates if IC1/IC2 is operating or no operating. When busy flag is high, it is in internal operating. When busy flag is low, it can accept the data or instruction.

DB7 indicates busy flag of the KS0108B.

POWER LIGHT

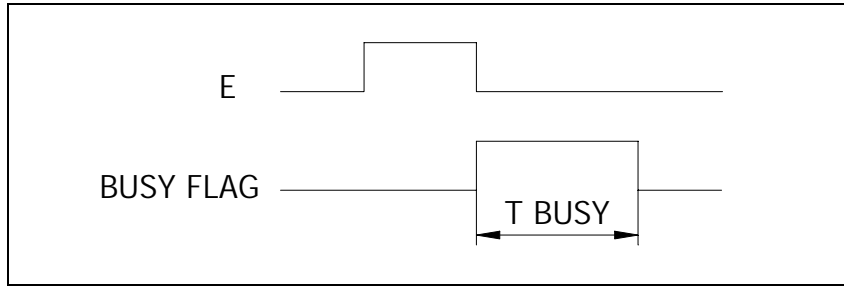

### 8.5 DISPLAY DATA RAM MAP

PAGE (X) ADDRESS	DISPLAY DATA	IC1(CS1)				Y ADDRESS				IC2(CS2)				Y ADDRESS		Z ADDRESS		
		0	1	2	3	...	...	62	63	0	1	2	3	...	...		62	63
0	DB0																	Z ADDRESS DENOTES WHICH LINE OF THE RAM WILL BE APPEAR ON THE FIRST LINE OF THE LCD PANEL
	DB1																	
	DB2																	
	DB3																	
	DB4																	
	DB5																	
	DB6																	
	DB7																	
1	DB0																	
	DB1																	
	DB2																	
	DB3																	
	DB4																	
	DB5																	
	DB6																	
	DB7																	
.	.	.	.	.	.	.	.	.	.	.	.	.	.	.	.	.	.	
	.	.	.	.	.	.	.	.	.	.	.	.	.	.	.	.	.	
	.	.	.	.	.	.	.	.	.	.	.	.	.	.	.	.	.	
	.	.	.	.	.	.	.	.	.	.	.	.	.	.	.	.	.	
7	DB0																	
	DB1																	
	DB2																	
	DB3																	
	DB4																	
	DB5																	
	DB6																	
	DB7																	

## 9. INSPECTION STANDARDS

### 9.1 Inspection Conditions

The LCD shall be inspected under 40W white fluorescent light.

The distance between the eyes and the samples shall be more than 30cm.

All directions for inspecting the sample should be within 45 degree against perpendicular line.

POWER LIGHT

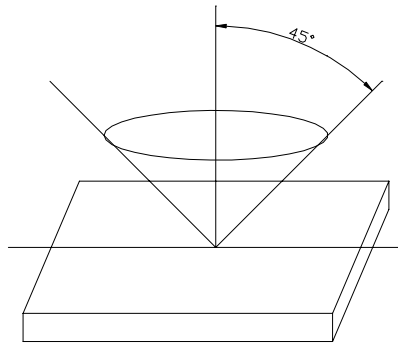

## 9.2 Definition of Applicable Zone

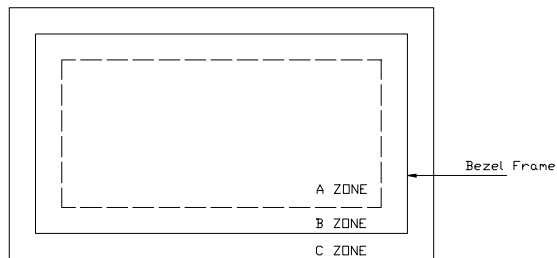

- A Zone: Active Display Area
- B Zone: Area from Bezel Frame to A Zone
- C Zone: Rest Area of Bezel
- A Zone + B Zone=Effective Viewing Area

## 9.3 Standards

NO	PARAMETER	CRITERIA			
1	Black and White Spots, Foreign Substances	Round Shape			
		DIMENSION(MM)	Zone		
			Acceptable Number		
			A	B	C
	$D \leq 0.1$	*	*	*	
	$0.1 < D \leq 0.2$	5	5	*	
	$0.2 < D \leq 0.3$	0	1	*	

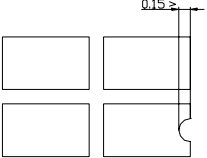
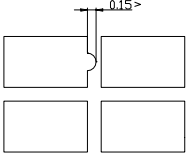
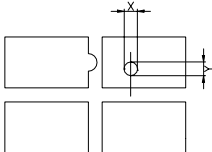
		<table border="1"> <tr> <td><math>0.3 &lt; D</math></td> <td>0</td> <td>0</td> <td>*</td> </tr> </table> <p><math>D = (\text{long} + \text{short}) / 2</math> * Disregard</p> <p><b>Line Shape</b></p> <table border="1"> <thead> <tr> <th colspan="2" rowspan="2">Zone X(mm) \ Y(mm)</th> <th colspan="3">Acceptable Number</th> </tr> <tr> <th>A</th> <th>B</th> <th>C</th> </tr> </thead> <tbody> <tr> <td>-</td> <td><math>0.02 \geq W</math></td> <td>*</td> <td>*</td> <td>*</td> </tr> <tr> <td><math>2.0 \geq L</math></td> <td><math>0.03 \geq W</math></td> <td>3</td> <td>3</td> <td>*</td> </tr> <tr> <td><math>1.0 \geq L</math></td> <td><math>0.04 \geq W</math></td> <td>1</td> <td>2</td> <td>*</td> </tr> <tr> <td><math>1.0 \geq L</math></td> <td><math>0.05 \geq W</math></td> <td>0</td> <td>2</td> <td>*</td> </tr> <tr> <td>-</td> <td><math>0.05 &lt; W</math></td> <td colspan="3">Not acceptable</td> </tr> </tbody> </table> <p>X: Length Y: Width * Disregard</p> <p>Total defects shall not exceed 5.</p>	$0.3 < D$	0	0	*	Zone X(mm) \ Y(mm)		Acceptable Number			A	B	C	-	$0.02 \geq W$	*	*	*	$2.0 \geq L$	$0.03 \geq W$	3	3	*	$1.0 \geq L$	$0.04 \geq W$	1	2	*	$1.0 \geq L$	$0.05 \geq W$	0	2	*	-	$0.05 < W$	Not acceptable		
$0.3 < D$	0	0	*																																				
Zone X(mm) \ Y(mm)		Acceptable Number																																					
		A	B	C																																			
-	$0.02 \geq W$	*	*	*																																			
$2.0 \geq L$	$0.03 \geq W$	3	3	*																																			
$1.0 \geq L$	$0.04 \geq W$	1	2	*																																			
$1.0 \geq L$	$0.05 \geq W$	0	2	*																																			
-	$0.05 < W$	Not acceptable																																					
2	Air Bubbles (Between glass and polarizer)	<table border="1"> <thead> <tr> <th rowspan="2">Dimension(mm)</th> <th colspan="3">Zone</th> </tr> <tr> <th>A</th> <th>B</th> <th>C</th> </tr> </thead> <tbody> <tr> <td><math>D \leq 0.1</math></td> <td>*</td> <td>*</td> <td>*</td> </tr> <tr> <td><math>0.1 &lt; D \leq 0.2</math></td> <td>5</td> <td>5</td> <td>*</td> </tr> <tr> <td><math>0.2 &lt; D \leq 0.3</math></td> <td>0</td> <td>1</td> <td>*</td> </tr> <tr> <td><math>0.3 &lt; D</math></td> <td>0</td> <td>0</td> <td>*</td> </tr> </tbody> </table> <p>*: Disregard</p> <p>Total defects shall not exceed 3.</p>	Dimension(mm)	Zone			A	B	C	$D \leq 0.1$	*	*	*	$0.1 < D \leq 0.2$	5	5	*	$0.2 < D \leq 0.3$	0	1	*	$0.3 < D$	0	0	*														
Dimension(mm)	Zone																																						
	A	B	C																																				
$D \leq 0.1$	*	*	*																																				
$0.1 < D \leq 0.2$	5	5	*																																				
$0.2 < D \leq 0.3$	0	1	*																																				
$0.3 < D$	0	0	*																																				
3	The Shape of Dot	<p>(1) Dot Shape(with dent)</p>  <p>As per the sketch of left hand.</p> <p>(2) Dot Shape(with Projection)</p>  <p>Should not connect to next dot.</p> <p>(3) Pin Hole</p>  <p><math>(X+Y)/2 &lt; 0.2\text{mm}</math> (less than 0.1mm is not counted)</p>																																					

		Total defects shall not exceed 5.
4	Polarizer Scratches	Not to be conspicuous defects.
5	Polarizer Dirts	If the stains are removed easily from LCD surface, the module is not defective.
6	Color Variation	Not to be conspicuous defects.

## 10. PRECAUTIONS IN USING LCM

### 1. LIQUID CRYSTAL DISPLAY (LCD)

LCD is made up of glass, organic sealant, organic fluid, and polymer based polarizers. The following precautions should be taken when handling,

- (1). Keep the temperature within range of use and storage. Excessive temperature and humidity could cause polarization degradation, polarizer peel off or bubble.
- (2). Do not contact the exposed polarizers with anything harder than an HB pencil lead. To clean dust off the display surface. Wipe gently with cotton. Chamois or other soft material soaked in petroleum benzin.
- (3). Wipe off saliva or water drops immediately. Contact with water over a long period of time may cause polarizer deformation or color fading, while an active LCD with water condensation on its surface will cause corrosion of ITO electrodes.
- (4). Glass can be easily chipped or cracked from rough handling. especially at corners and edges.
- (5). Do not drive LCD with DC voltage.

### 2. Liquid Crystal Display Modules

#### 2.1 Mechanical Considerations

LCM are assembled and adjusted with a high degree of precision. Avoid excessive shocks and do not make any alterations or modifications. The following should be noted.

- (1). Do not tamper in any way with the tabs on the metal frame.
- (2). Do not modify the PCB by drilling extra holes, changing its outline, moving its components or modifying its pattern.
- (3). Do not touch the elastomer connector, especially insert a backlight panel (for example, EL).
- (4). When mounting a LCM make sure that the PCB is not under any stress such as bending or twisting. Elastomer contacts are very delicate and missing pixels could result from slight dislocation of any of the elements.
- (5). Avoid pressing on the metal bezel, otherwise the elastomer connector could be deformed and lose contact, resulting in missing pixels.

#### 2.2. Static Electricity

LCM contains CMOS LSI's and the same precaution for such devices should apply, namely

- (1). The operator should be grounded whenever he/she comes into contact with the module. Never touch any of the conductive parts such as the LSI pads, the copper leads on the PCB and the interface terminals with any parts of the human body.
- (2). The modules should be kept in antistatic bags or other containers resistant to static for storage.
- (3). Only properly grounded soldering irons should be used.

- (4). If an electric screwdriver is used, it should be well grounded and shielded from commutator sparks.
- (5). The normal static prevention measures should be observed for work clothes and working benches; for the latter conductive ( rubber) mat is recommended.
- (6). Since dry air is inductive to statics, a relative humidity of 50-60% is recommended.

### **2.3. Soldering**

- (1). Solder only to the I/O terminals.
- (2). Use only soldering irons with proper grounding and no leakage.
- (3). Soldering temperature:  $280\text{ }^{\circ}\text{C} \pm 10^{\circ}\text{C}$
- (4). Soldering time: 3 to 4 sec.
- (5). Use eutectic solder with resin flux fill.
- (6). If flux is used, the LCD surface should be covered to avoid flux spatters. Flux residue should be removed after wards.

### **2.4. Operation**

- (1). The viewing angle can be adjusted by varying the LCD driving voltage  $V_0$ .
- (2). Driving voltage should be kept within specified range; excess voltage shortens display life.
- (3). Response time increases with decrease in temperature.
- (4). Display may turn black or dark blue at temperatures above its operational range; this is (however not pressing on the viewing area) may cause the segments to appear "fractured".
- (5). Mechanical disturbance during operation (such as pressing on the viewing area) may cause the segments to appear "fractured".

### **2.5. Storage**

If any fluid leaks out of a damaged glass cell, wash off any human part that comes into contact with soap and water. Never swallow the fluid. The toxicity is extremely low but caution should be exercised at all the time.

**THE END**

POWER LIGHT