

POWER LIGHT™

LCD MODULE SPECIFICATIONS

PL-C2045A SERIES

20 CHARACTERS X 4 LINES

OUTLINE DIMENSION: 65.0 X 28.4 MM

VIEWING AREA: 46.0 X 18.4 MM

CHARACTER SIZE: 1.85 X 3.15 MM

REVISION RECORD

REV.	DATE	PAGE	COMMENT
A	2003-8-26		NEW RELEASE
B	2003-9-12	P5/P6	DRIVING VOLTAGE 3.0/5.0V
C	2003-9-16	P7	ADD 3.0V SPEC.
D	2004-8-14	P6	MODIFICATION FOR 3.3V WORKING

CONTENTS

1. LCD MODULE NUMBERING SYSTEM
2. MECHANICAL CHARACTERISTICS
 - 2.1 MECHANICAL DATA
 - 2.2 MECHANICAL DRAWINGS

- 3. CIRCUIT BLOCK DIAGRAM
 - 3.1 Electrical Block Diagram
 - 3.2 Pins Definition
 - 3.3 Power Supply For LCM Driving
 - 3.3 Display Character Address Code
- 4. ABSOLUTE MAXIMUM RATINGS
 - 4.1 Electrical Absolute Maximum Ratings
 - 4.2 Environmental Absolute Maximum Ratings
- 5. ELECTRICAL CHARACTERISTICS
 - 5.1 DC Characteristics
 - 5.2 AC Characteristics
- 6. BACKLIGHT CHARACTERISTICS
 - 6.1 Absolute Maximum Ratings
 - 6.2 Operating Parameters
- 7. ELECTRO-OPTICAL CHARACTERISTIC
- 8. DISPLAY CONTROL INSTRUCTION
 - 8.1 INSTRUCTION TABLE
 - 8.2 Character Table
- 9. INSPECTION STANDARDS
- 10. PRECAUTIONS IN USING LCM

1. LCD MODULE NUMBERING SYSTEM

PART NUMBER: PL-AB...BC-DEFGHI-JK

PL POWER LIGHT TECHNOLOGY
A DISPLAY CONTENTS S---SEGMENT TYPE
 C---CHARACTER TYPE
 G---GRAPHIC TYPE

B...B SERIALS NUMBER FOR SM
 CHARACTERS Vs. LINES FOR CM

POWER LIGHT

C COLUMNS Vs. ROWS FOR GM
D VERSION OF PCB
 LCD TYPE
 P---POS. TN, N---NEG. TN, Y---YELLOW STN, G---GRAY STN
 B---BLUE STN, F---FSTN
E POLARIZER TYPE
 R---REFLECTIVE, F---TRANSFLECTIVE, T---TRANSMISSIVE
F VIEWING ANGLE S---6 O'CLOCK, T---12 O'CLOCK
G OPERATING TEMPRETURE N---NORMAL, E---EXTENDED
H BACKLIGHT TYPE N---NO BACKLIGHT, D---BOTTOM LED, S---SIDE LED,
 E---EL, C---CCFL
I COLOR OF BACKLIGHT Y---YELLOW/GREEN, G---GREEN
 W---WHITE, B---BLUE, A---AMBER
JK FOR CM, CONTROLLER/DRIVER DESIGNATOR
 J: IC A---KS0066U B---SPLC780
 K: DENOTE DIFFERENT CHARACTER TABLE
 FOR GM. J: BACKLIGHT DRIVER Y---WITH, N---WITHOUT
 K: DC-DC CONVERTER Y---WITH, N---WITHOUT

2. MECHANICAL CHARACTERISTICS

2.1 MECHANICAL DATA

ITEM	STANDARD VALUE	UNIT
NUMBER OF CHARACTERS	20 CHARACTERS X 4 LINES	
CHARACTER FORMAT	5 X 7 DOTS PLUS CURSOR	
OUTLINE DIMENSIONS	65.0(W) X 28.4(H) X 9.0(T)	mm
EFFECTTVE VIEWING AREA	46.0(W) X 18.4(H)	mm
CHARACTER SIZE	1.85(W) X 3.15(H)	mm
CHARACTER PITCH	2.15(W) X 4.25(H)	mm
DOT SIZE	0.33(W) X 0.35(H)	mm
DOT PITCH	0.38(W) X 0.40(H)	mm
APPROX WEIGHT	TBD	g

2.2 MECHANICAL DRAWINGS

POWER LIGHT

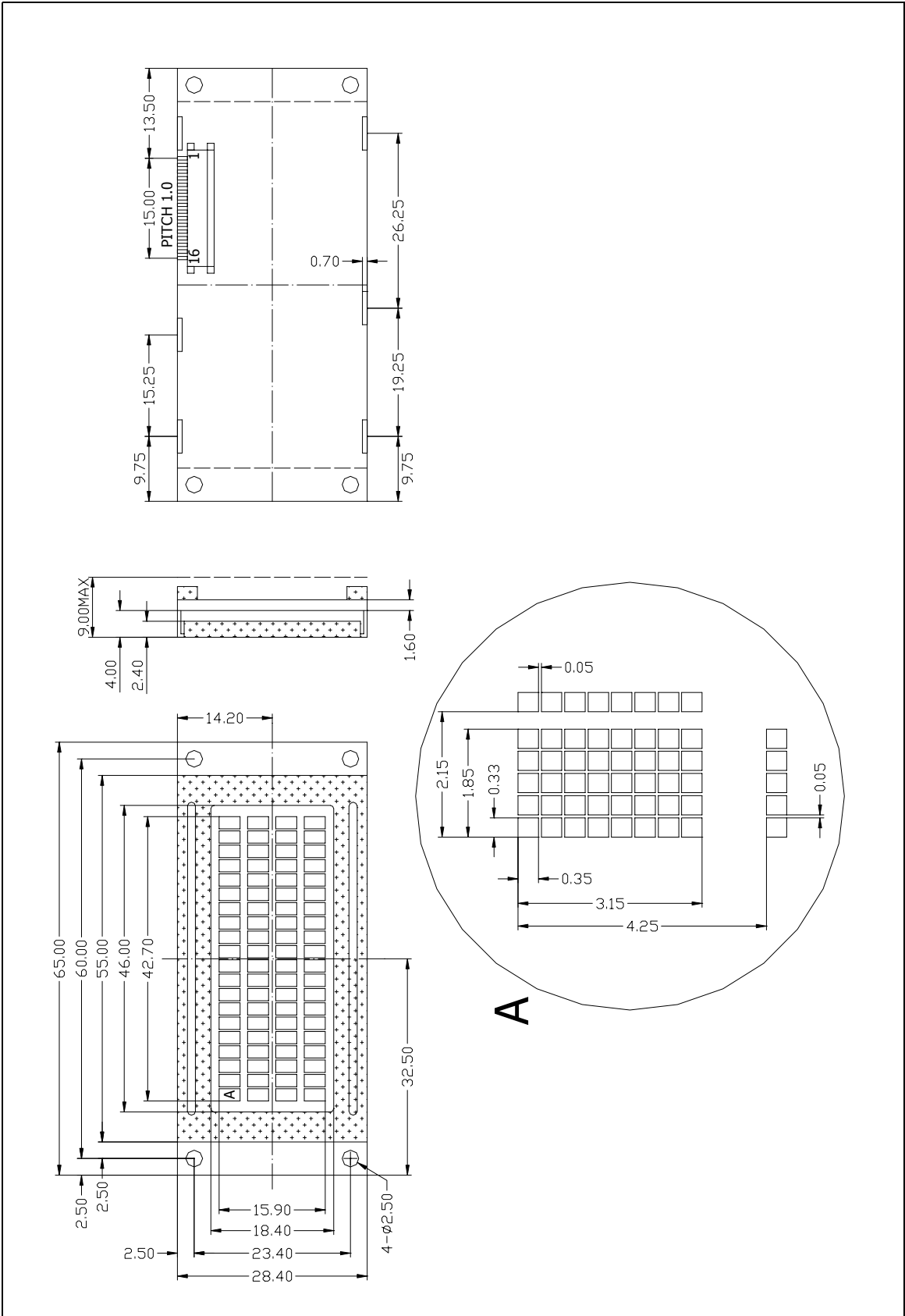

3. CIRCUIT BLOCK DIAGRAM

3.1 Electrical Block Diagram

POWER LIGHT

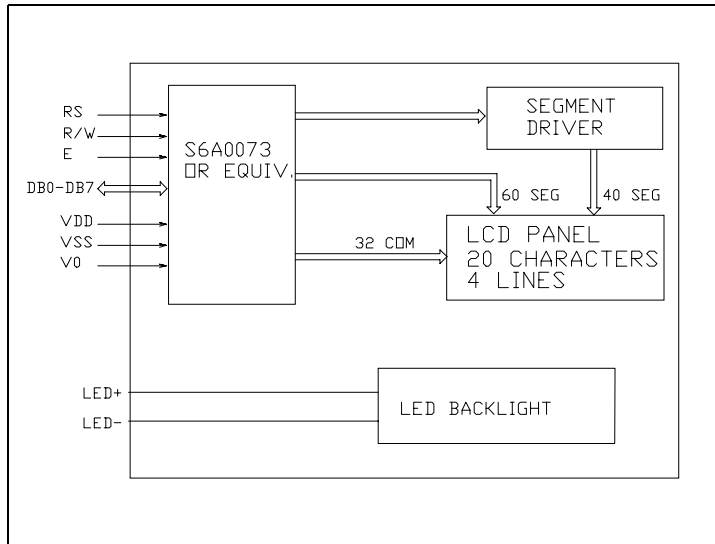

3.2 Pins Definition

PIN	SYMBOL	FUNCTION
1	Vss	Power Supply(GND)
2	Vdd	Power Supply(+5.0/+3.0V)
3	Vo	Input Voltage to Booster
4	RS	Instruction/Data Register Select
5	R/W	Data Bus Line
6	E	Enable Signal
7-14	DB0-DB7	Data Bus Line
15	A	Power Supply for LED B/L(+)
16	K	Power Supply for LED B/L(-)

3.3 Power Supply For LCM Driving

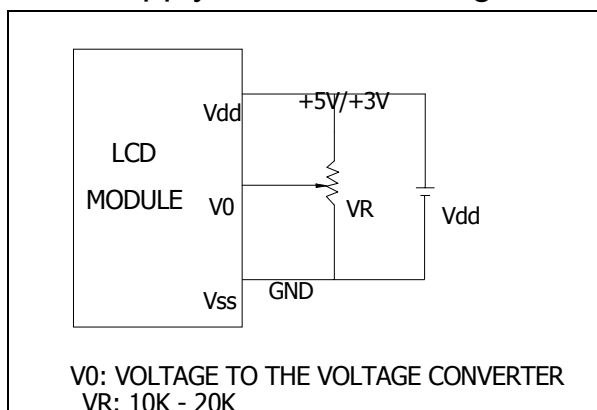

NOTE: When working at 3.3V, please change R2 from 1.0K to 0 OHM

3.4 Display Character Address Code

LIGHT

POWER

POSITION	1	2	3	4	5	6	7	8	9	10	11	12	13	14	15	16	17	18	19	20	
ADDRESS	LINE1	00	01	02	03	04	05	06	07	08	09	0A	0B	0C	0D	0E	0F	10	11	12	13
	LINE2	20	21	22	23	24	25	26	27	28	29	2A	2B	2C	2D	2E	2F	30	31	32	33
	LINE3	40	41	42	43	44	45	46	47	48	49	4A	4B	4C	4D	4E	4F	50	51	52	53
	LINE4	60	61	62	63	64	65	66	67	68	69	6A	6B	6C	6D	6E	6F	70	71	72	73

*NOTE: ALL OF THE NUMBERS ARE IN HEX FORMAT

4. ABSOLUTE MAXIMUM RATINGS

4.1 Electrical Absolute Maximum Ratings

ITEM	SYMBOL	CONDITION	MIN	MAX	UNIT
Supply Voltage (Logic)	Vdd – Vss	-	0	6.0	V
Supply voltage for LCD driving	Vlcd	-	Vdd-15	Vdd+0.3	V
Input Voltage	Vi	-	0	Vdd	V

4.2 Environmental Absolute Maximum Ratings

ITEM	SYMBOL	CONDITIONS	MIN	MAX	UNIT
Operating Temp	Topr	-Normal temp.	0	50	deg C
Storage Temp	Ttsg	version-	-20	70	deg C
Operating Temp	Topr	Extended temp.	-20	70	deg C
Storage Temp	Ttsg	version	-30	80	deg C
Humidity Endurance	RH	no ondensation Ta<=40 deg	-	95	%
Vibration	-	100-300Hz, X/Y/Z directions, 1 hour	-	4.9m/ss 0.5g	-
Shock	-	10 mS X/Y/Z direction 1 time each	-	29.4m/ss 3.0g	-

5. ELECTRICAL CHARACTERISTICS

5.1 DC Characteristics

Electrical Characteristics at Ta=-30 to 85 deg C, Vdd =2.7V to 5.5V

ITEM	SYMBOL	CONDITION	MIN	TYP	MAX	UNIT
------	--------	-----------	-----	-----	-----	------

Supply Voltage (logic)	Vdd-Vss	-	2.7	-	5.5	V
Supply Voltage (LCD)	V0	Vdd = 5.0V	-	2.5	-	V
		Vdd=3.0V	-	2.3	-	V
Input signal Voltage (for E, DB0-7,R/W,RS)	V-ih	"H" level	0.7Vdd	-	Vdd	V
	V-il	"L" level	0	-	0.6	V
Supply Current (logic)	Icc	-	-	0.15	0.3	mA
Supply Current (LCD)	Io	-	-	0.6	1.3	mA

5.2 AC Characteristics

TIMING SPECIFICATIONS at Ta = -30 to 80 deg C, Vdd = 2.7 to 4.5V,

For Write mode

ITEM	SYMBOL	MIN	MAX	UNIT
E cycle time	tc	1000	-	ns
E rise time	tR	-	25	ns
E fall time	tF	-	25	ns
E-pulse width (H, L)	tw	450	-	ns
R/W and RS set-up time	tsul	60	-	ns
R/W and RS hold time	tH1	20	-	ns
Data set-up time	tsu2	195	-	ns
Data hold time	tH2	10	-	ns

For Read mode

ITEM	SYMBOL	MIN	MAX	UNIT
E cycle time	tc	1000	-	ns
E rise time	tR	-	25	ns

E fall time	tF	-	25	ns
E-pulse width (H, L)	tw	450	-	ns
R/W and RS set-up time	tsu	60	-	ns
R/W and RS hold time	tH	20	-	ns
Data output delay	tD	-	360	ns
Data hold time	tDH	5	-	ns

WRITE MODE TIMING DIAGRAM

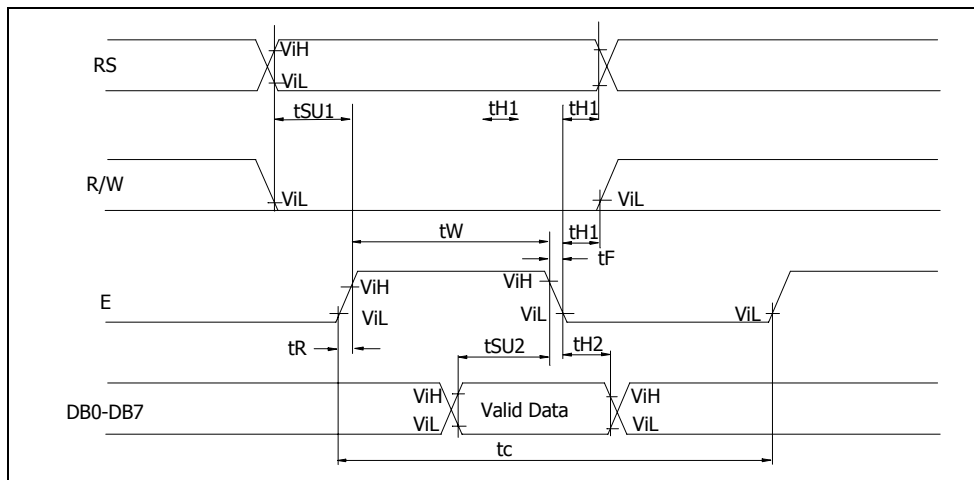

READ MODE TIMING DIAGRAM

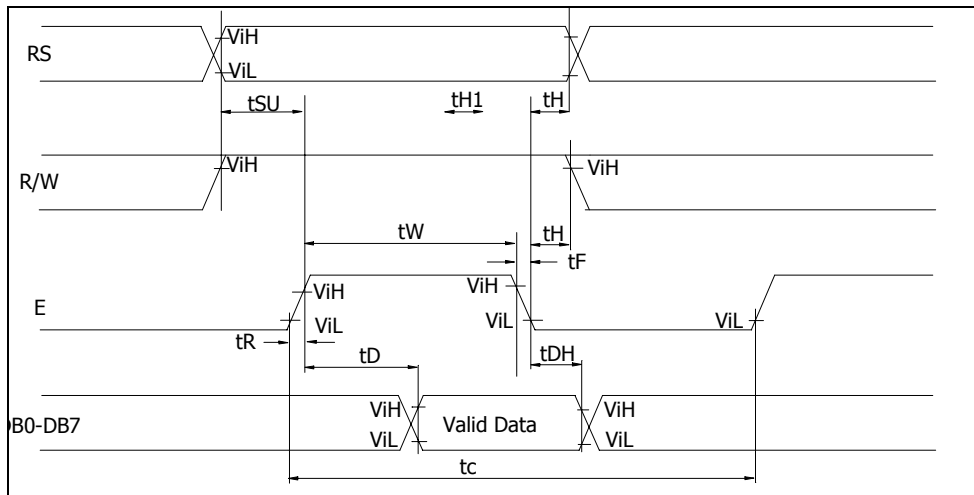

6. BACKLIGHT CHARACTERISTICS

6.1 Absolute Maximum Ratings

ITEM	SYMBOL	CONDITION	MIN	MAX	UNIT
------	--------	-----------	-----	-----	------

POWER LIGHT

Forward Current	Ifm	-	-	80	mA
Reverse Voltage	Vr	-	-	8	V
Power Dissipation	Pd	-	-	TBD	mW

6.2 Operating Parameters

ITEM	SYMBOL	CONDITION	MIN	TYP.	MAX	UNIT
Forward Voltage	Vf	If=100mA-	3.9	4.1	4.3	V
Peak Wavelength	λ	If=100mA-	-	568	-	nm

7. ELECTRO-OPTICAL CHARACTERISTICS

(S) FOR STN TYPE, (T) FOR TN TYPE

ITEM	SYMBOL	CONDITION	MIN.	TYP.	MAX.	UNIT	REF.
Contrast	CR	25°C	--	12(S)/3(T)	--		Note1
Rise Time	tr	25°C	--	160	240	ms	Note2
Fall Time	tf	25°C	--	100	150	ms	note 2
Viewing Angle	$\theta 1 - \theta 2$ $\varnothing 1, \varnothing 2$	25°C	-- -40(S)/-15(T)	--	60(S)/20(T) 40(S)/15(T)	DEG	Note 3
Frame Frequency	Ff	25°C	--	70	--	Hz	note 2

Note(1): Contrast ratio is defined under the following condition:

CR= $\frac{\text{brightness of selected condition}}{\text{brightness of non-selected condition}}$

- (a). Temperature-----25C
- (b). Frame Frequency-----64Hz
- (c). Viewing angle----- $\theta = 0, \varnothing = 0$
- (d). Operating Voltage---5.0V

Note(2): definition of response time:

POWER LIGHT

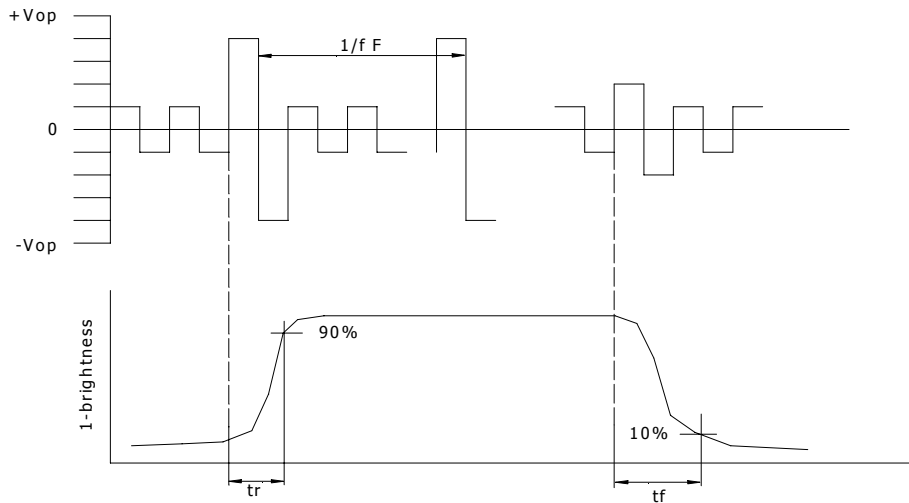

Condition:

- (a). Temperature-----25C
- (b). Frame Frequency-----64Hz
- (c). Viewing angle----- $\theta = 0, \phi = 0$
- (d). Operating Voltage---5.0V

Note(3): definition of view angle:

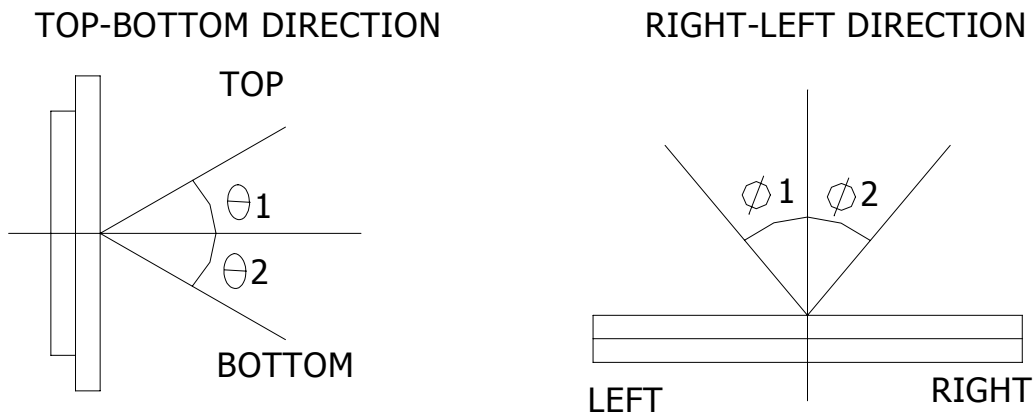

8. DISPLAY CONTROL INSTRUCTION

8.1 INSTRUCTION TABLE

Function	R	R	R	D	D	D	D	D	D	D	D	D	D	Description	Execution Time*
	E	S	W	B	B	B	B	B	B	B	B	B	B		

				7	6	5	4	3	2	1	0		(Max)	
Clear Display	X	0	0	0	0	0	0	0	0	0	1	Write "20H" to DDRAM and set DRAM address to "00H" from AC	1.53mS	
Return Home	X	0	0	0	0	0	0	0	0	1	X	Return the cursor to the home position. DD RAM contents remain unchanged. Set DD RAM address to "00H"	1.53mS	
Entry mode set	X	0	0	0	0	0	0	0	1	I	S / D	Set cursor moving direction and enable the shift of the display. 1/D=1: increment; 1/D=0: decrement; S=1: whole display shift when data is written. S=0: display shift disable	39 μ S μ S	
Display ON/OFF control	0	0	0	0	0	0	0	1	D	C	B	Set display (D),cursor(C) and blinking of cursor(B) ON/OFF. D=1:display ON; D=0: display OFF. C=1:Cursor ON; C=0: cursot OFF. B=1:Blink ON; B=0, Blink OFF.	39 μ S μ S	
Extended function set	1	0	0	0	0	0	1	F	B	N	W	W	Assign font width, black/white inverting of cursor, and 4-line display mode control bit. FW=1:6-dot font width; FW=0: 5-dot font width;BW=1: black/white inverting of cursor enable; BW=0: black/white inverting of cursor disable; NW=1: 4-line display mode; NW=0: 1-line or 2-line display mode	39 μ S
Cursor or Display shift	0	0	0	0	0	1	S	R	X	X	/ / C L	Move the cursor and shift the display without changing DDRAM contents. S/C=1: Display Shift; S/C=0:Cursor move. R/L=1:shift to right; R/L=0:shift to left.	39 μ S	
Scroll enable	1	0	0	0	0	1	H	H	H	H	S	S	Determine the line for horizontal smooth scroll. HS1=1/0: 1 st line dot scroll enable/disable HS2=1/0: 2nd line dot scroll enable/disable HS3=1/0: 3rd line dot scroll enable/disable HS4=1/0: 4th line dot scroll enable/disable	
Function Set	0	0	0	0	1	D	N	R	X	X	L	E	Set interface data length (DL), number of display lines (N) and extention register RE=0. DL=1: 8 bits; DL=0: 4 bits. N=1: 2 lines; N=0: 1 lines.	39 μ S
	1	0	0	0	1	D	N	R	B	L	L	E	Set DL,N,RE("1") and CGRAM/SEGRAM blink enable(BE) BE=1/0: blink enable/disable; LP=1: low power mode; LP=0: normal operation mode	
Set CG RAM add	0	0	0	1	A	A	A	A	A	A	A	A	Set CG RAM address. CG RAM data is sent and received after this setting.	39 μ S
Set SEGRAM address	1	0	0	1	x	x	A	A	A	A	A	A	Set SEGRAM address in address counter	39 μ S
Set DD RAM Address	0	0	1	A	A	A	A	A	A	A	A	A	Set DD RAM address. DD RAM data is sent and received after this setting.	39 μ S

POWER LIGHT

Set scroll quantity	1	0	0	1	x	S	S	S	S	S	S	Set the quantity of horizontal dot scroll	39 μ S
						Q	Q	Q	Q	Q	Q		
						5	4	3	2	1	0		
Read BF & Addr	x	0	1	B		AC					Read BUSY FLAG (BF) and the contents of the address counter. BF=1: internal operation; BF=0: can accept instruction.	0 μ S	
Write Data to RAM	x	1	0			WRITE DATA					Write data into DD RAM or CG RAM.	43 μ S	
Read Data from RAM	x	1	0			READ DATA					Read data from DD RAM or CG RAM.	43 μ S	

8.2 Character Table

POWER LIGHT

9. INSPECTION STANDARDS

9.1 Inspection Conditions

The LCD shall be inspected under 40W white fluorescent light.

The distance between the eyes and the samples shall be more than 30cm.

All directions for inspecting the sample should be within 45 degree against perpendicular line.

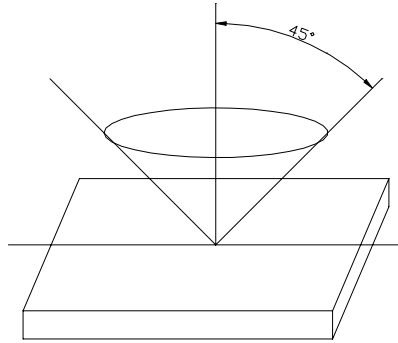

9.2 Definition of Applicable Zone

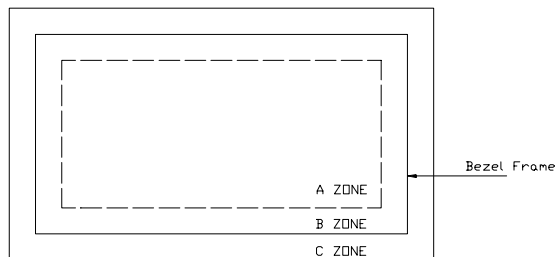

A Zone: Active Display Area

B Zone: Area from Bezel Frame to A Zone

C Zone: Rest Area of Bezel

A Zone + B Zone=Effective Viewing Area

9.3 Standards

NO	PARAMETER	CRITERIA			
1	Black and White Spots, Foreign Substances	Round Shape			
		Zone	Acceptable Number		
		DIMENSION(MM)	A	B	C
		$D \leq 0.1$	*	*	*
$0.1 < D \leq 0.2$	5	5	*		

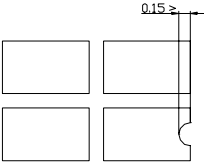
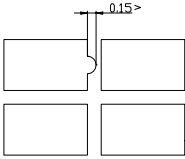
		<table border="1"> <tr> <td>$0.2 < D \leq 0.3$</td> <td>0</td> <td>1</td> <td>*</td> </tr> <tr> <td>$0.3 < D$</td> <td>0</td> <td>0</td> <td>*</td> </tr> </table> <p>$D = (\text{long} + \text{short}) / 2$ * Disregard</p> <p>Line Shape</p> <table border="1"> <thead> <tr> <th rowspan="2">X(mm)</th> <th rowspan="2">Y(mm)</th> <th colspan="3">Zone</th> </tr> <tr> <th colspan="3">Acceptable Number</th> </tr> <tr> <th colspan="2"></th> <th>A</th> <th>B</th> <th>C</th> </tr> </thead> <tbody> <tr> <td>-</td> <td>$0.02 \geq W$</td> <td>*</td> <td>*</td> <td>*</td> </tr> <tr> <td>$2.0 \geq L$</td> <td>$0.03 \geq W$</td> <td>3</td> <td>3</td> <td>*</td> </tr> <tr> <td>$1.0 \geq L$</td> <td>$0.04 \geq W$</td> <td>1</td> <td>2</td> <td>*</td> </tr> <tr> <td>$1.0 \geq L$</td> <td>$0.05 \geq W$</td> <td>0</td> <td>2</td> <td>*</td> </tr> <tr> <td>-</td> <td>$0.05 < W$</td> <td colspan="3">Not acceptable</td> </tr> </tbody> </table> <p>X: Length Y: Width * Disregard</p> <p>Total defects shall not exceed 5.</p>	$0.2 < D \leq 0.3$	0	1	*	$0.3 < D$	0	0	*	X(mm)	Y(mm)	Zone			Acceptable Number					A	B	C	-	$0.02 \geq W$	*	*	*	$2.0 \geq L$	$0.03 \geq W$	3	3	*	$1.0 \geq L$	$0.04 \geq W$	1	2	*	$1.0 \geq L$	$0.05 \geq W$	0	2	*	-	$0.05 < W$	Not acceptable		
$0.2 < D \leq 0.3$	0	1	*																																													
$0.3 < D$	0	0	*																																													
X(mm)	Y(mm)	Zone																																														
		Acceptable Number																																														
		A	B	C																																												
-	$0.02 \geq W$	*	*	*																																												
$2.0 \geq L$	$0.03 \geq W$	3	3	*																																												
$1.0 \geq L$	$0.04 \geq W$	1	2	*																																												
$1.0 \geq L$	$0.05 \geq W$	0	2	*																																												
-	$0.05 < W$	Not acceptable																																														
2	Air Bubbles (Between glass and polarizer)	<table border="1"> <thead> <tr> <th rowspan="2">Dimension(mm)</th> <th colspan="3">Zone</th> </tr> <tr> <th>A</th> <th>B</th> <th>C</th> </tr> </thead> <tbody> <tr> <td>$D \leq 0.1$</td> <td>*</td> <td>*</td> <td>*</td> </tr> <tr> <td>$0.1 < D \leq 0.2$</td> <td>5</td> <td>5</td> <td>*</td> </tr> <tr> <td>$0.2 < D \leq 0.3$</td> <td>0</td> <td>1</td> <td>*</td> </tr> <tr> <td>$0.3 < D$</td> <td>0</td> <td>0</td> <td>*</td> </tr> </tbody> </table> <p>*: Disregard</p> <p>Total defects shall not exceed 3.</p>	Dimension(mm)	Zone			A	B	C	$D \leq 0.1$	*	*	*	$0.1 < D \leq 0.2$	5	5	*	$0.2 < D \leq 0.3$	0	1	*	$0.3 < D$	0	0	*																							
Dimension(mm)	Zone																																															
	A	B	C																																													
$D \leq 0.1$	*	*	*																																													
$0.1 < D \leq 0.2$	5	5	*																																													
$0.2 < D \leq 0.3$	0	1	*																																													
$0.3 < D$	0	0	*																																													
3	The Shape of Dot	<p>(1) Dot Shape(with dent)</p>  <p>As per the sketch of left hand.</p> <p>(2) Dot Shape(with Projection)</p>  <p>Should not connect to next dot.</p> <p>(3) Pin Hole</p>																																														

POWER LIGHT

		<p>(X+Y)/2<0.2mm (less than 0.1mm is not counted)</p> <p>Total defects shall not exceed 5.</p>
4	Polarizer Scratches	Not to be conspicuous defects.
5	Polarizer Dirts	If the stains are removed easily from LCD surface,the module is not defective.
6	Color Variation	Not to be conspicuous defects.

10. PRECAUTIONS IN USING LCM

1. LIQUID CRYSTAL DISPLAY (LCD)

LCD is made up of glass, organic sealant, organic fluid, and polymer based polarizers. The following precautions should be taken when handing,

- (1). Keep the temperature within range of use and storage. Excessive temperature and humidity could cause polarization degradation, polarizer peel off or bubble.
- (2). Do not contact the exposed polarizers with anything harder than an HB pencil lead. To clean dust off the display surface. Wipe gently with cotton. Chamois or other soft material soaked in petroleum benzin.
- (3). Wipe off saliva or water drops immediately. Contact with water over a long period of time may cause polarizer deformation or color fading, while an active LCD with water condensation on its surface will cause corrosion of ITO electrodes.
- (4). Glass can be easily chipped or cracked from rough handing. especially at corners and edges.
- (5). Do not drive LCD with DC voltage.

2. Liquid Crystal Display Modules

2.1 Mechanical Considerations

LCM are assembled and adjusted with a high degree of precision. Avoid excessive shocks and do not make any alterations or modifications. The following should be noted.

- (1). Do not tamper in any way with the tabs on the metal frame.
- (2). Do not modify the PCB by drilling extra holes, changing its outline, moving its components or modifying its patten.
- (3). Do not touch the elastomer connector, especially insert an backlight panel (for example, EL).
- (4). When mounting a LCM make sure that the PCB is not under any tress such as bending or twisting. Elastomer contacts are very delicate and missing pixels could result from slight dislocation of any of the elements.
- (5). Avoid pressing on the metal bezel, otherwise the elastomer connector could be deformed and lose contact, resulting in missing piels.

2.2. Static Electricity

LCM contains CMOS LSI's and the same precaution for such devices should apply, namely

- (1). The operator should be grounded whenever he/she comes into contact with the module. Never touch any of the conductive parts such as the LSI pads, the copper leads on

the PCB and the interface terminals with any parts of the human body.

- (2). The modules should be kept in antistatic bags or other containers resistant to static for storage.
- (3). Only properly grounded soldering irons should be used.
- (4). If an electric screwdriver is used, it should be well grounded and shielded from commutator sparks.
- (5). The normal static prevention measures should be observed for work clothes and working benches; for the latter conductive (rubber) mat is recommended.
- (6). Since dry air is inductive to statics, a relative humidity of 50-60% is recommended.

2.3. Soldering

- (1). Solder only to the I/O terminals.
- (2). Use only soldering irons with proper grounding and no leakage.
- (3). Soldering temperature: $280\text{ }^{\circ}\text{C} \pm 10^{\circ}\text{C}$
- (4). Soldering time: 3 to 4 sec.
- (5). Use eutectic solder with resin flux fill.
- (6). If flux is used, the LCD surface should be covered to avoid flux spatters. Flux residue should be removed after wards.

2.4. Operation

- (1). The viewing angle can be adjusted by varying the LCD driving voltage V_0 .
- (2). Driving voltage should be kept within specified range; excess voltage shortens display life.
- (3). Response time increases with decrease in temperature.
- (4). Display may turn black or dark blue at temperatures above its operational range; this is (however not pressing on the viewing area) may cause the segments to appear "fractured".
- (5). Mechanical disturbance during operation (such as pressing on the viewing area) may cause the segments to appear "fractured".

2.5. Storage

If any fluid leaks out of a damaged glass cell, wash off any human part that comes into contact with soap and water. Never swallow the fluid. The toxicity is extremely low but caution should be exercised at all the time.

End

POWER LIGHT