



- 3.1 Electrical Block Diagram
- 3.2 Pins Definition
- 3.3 Power Supply For LCM Driving
- 3.3 Display Character Address Code
- 4. ABSOLUTE MAXIMUM RATINGS
  - 4.1 Electrical Absolute Maximum Ratings
  - 4.2 Environmental Absolute Maximum Ratings
- 5. ELECTRICAL CHARACTERISTICS
  - 5.1 DC Characteristics
  - 5.2 AC Characteristics
- 6. BACKLIGHT CHARACTERISTICS
  - 6.1 Absolute Maximum Ratings
  - 6.2 Operating Parameters
- 7. ELECTRO-OPTICAL CHARACTERISTIC
- 8. DISPLAY CONTROL INSTRUCTION
  - 8.1 INSTRUCTION TABLE
  - 8.2 Character Table
  - 8.3 INITIALIZATION BY INSTRUCTION
  - 8.4 SOFTWARE EXAMPLES
- 9. INSPECTION STANDARDS
- 10. PRECAUTIONS IN USING LCM

## 1. LCD MODULE NUMBERING SYSTEM

**PART NUMBER: PL-AB...BC-DEFGHI-JK**

**PL** POWER LIGHT TECHNOLOGY  
**A** DISPLAY CONTENTS S---SEGMENT TYPE  
 C---CHARACTER TYPE  
 G---GRAPHIC TYPE  
**B...B** SERIALS NUMBER FOR SM  
 CHARACTERS Vs. LINES FOR CM  
 COLUMNS Vs. ROWS FOR GM  
**C** VERSION OF PCB  
**D** LCD TYPE  
 P---POS. TN, N---NEG. TN, Y---YELLOW STN, G---GRAY STN

POWER LIGHT

- E** B---BLUE STN, F---FSTN  
POLARIZER TYPE  
R---REFLECTIVE, F---TRANSFLECTIVE, T---TRANSMISSIVE
- F** VIEWING ANGLE S---6 O'CLOCK, T---12 O'CLOCK
- G** OPERATING TEMPRETURE N---NORMAL, E---EXTENDED
- H** BACKLIGHT TYPE N---NO BACKLIGHT, D---BOTTOM LED, S---SIDE LED,  
E---EL, C---CCFL
- I** COLOR OF BACKLIGHT Y---YELLOW/GREEN, G---GREEN  
W---WHITE, B---BLUE, A---AMBER
- JK** FOR CM, CONTROLLER/DRIVER DESIGNATOR  
J: IC A---KS0066U B---SPLC780  
K: DENOTE DIFFERENT CHARACTER TABLE  
FOR GM. J: BACKLIGHT DRIVER Y---WITH, N---WITHOUT  
K: DC-DC CONVERTER Y---WITH, N---WITHOUT

## 2. MECHANICAL CHARACTERISTICS

### 2.1 MECHANICAL DATA

ITEM	STANDARD VALUE	UNIT
NUMBER OF CHARACTERS	16 CHARACTERS X 1 LINES	
CHARACTER FORMAT	5 X 7 DOTS PLUS CURSOR	
OUTLINE DIMENSIONS	80.0(W) X 36.0(H) X 14.0/10.0(T)	mm
EFFECTTVE VIEWING AREA	64.5(W) X 16.4(H)	mm
CHARACTER SIZE	3.07(W) X 6.56(H)	mm
CHARACTER PITCH	3.77(W) X 6.56(H)	mm
DOT SIZE	0.55(W) X 0.75(H)	mm
DOT PITCH	0.63(W) X 083(H)	mm
APPROX WEIGHT	30(LED BL VERSION)/20(NO BL)	g

### 2.2 MECHANICAL DRAWINGS

POWER LIGHT

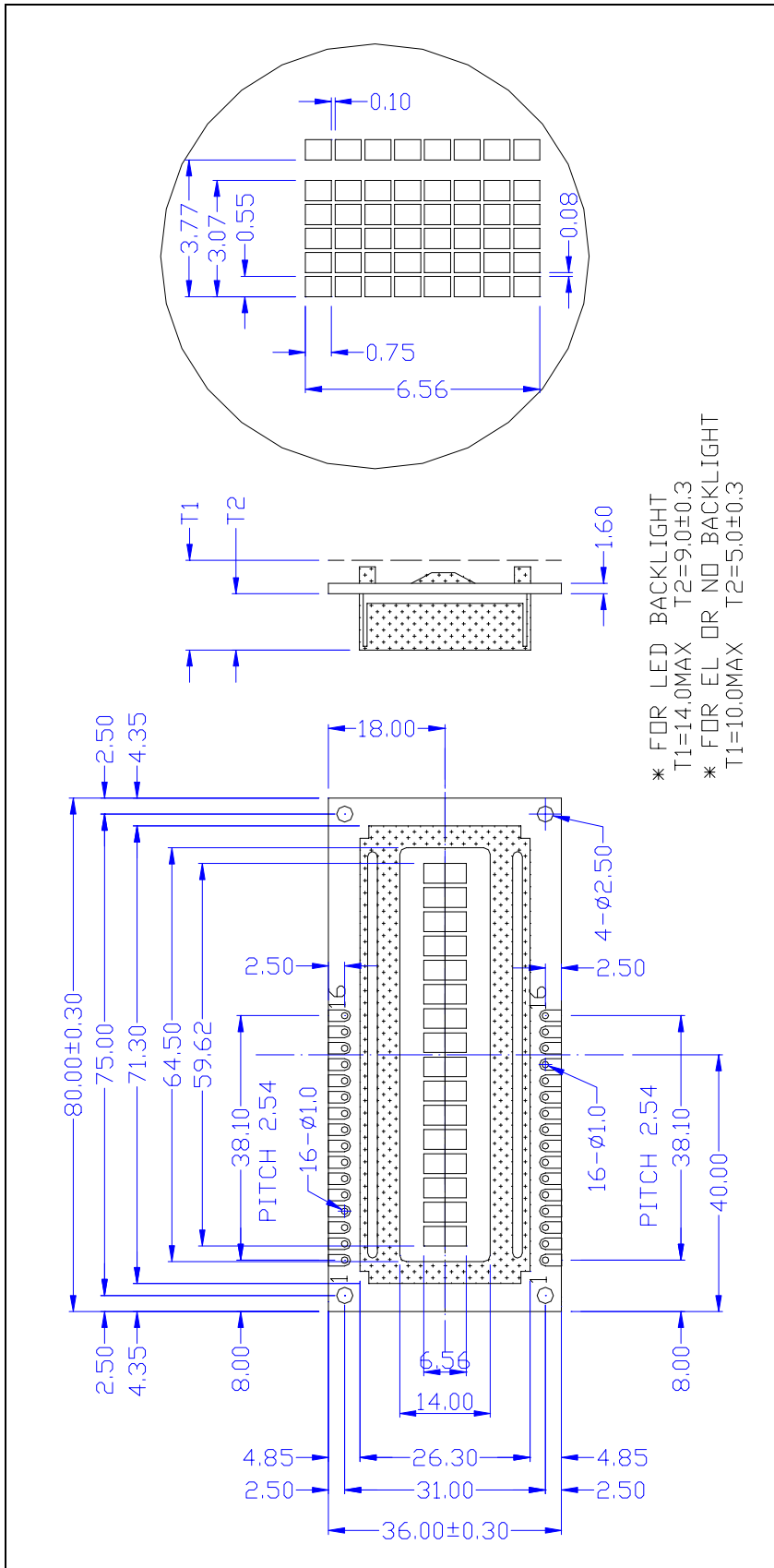

### 3. CIRCUIT BLOCK DIAGRAM

#### 3.1 Electrical Block Diagram

POWER LIGHT

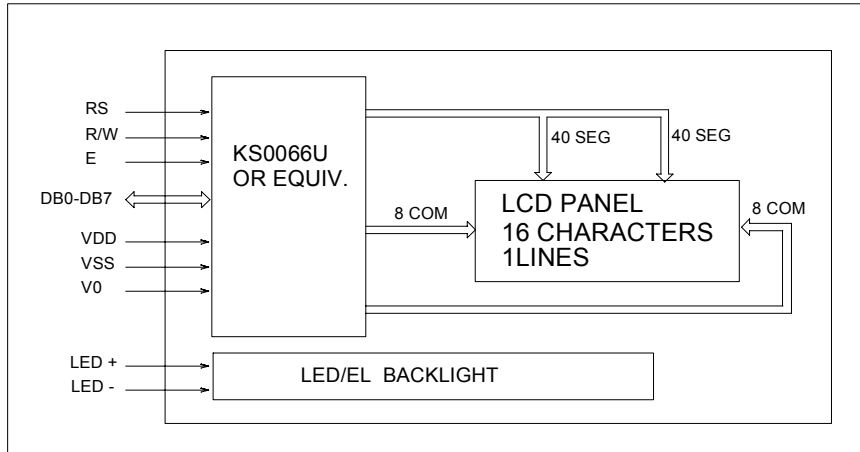

### 3.2 Pins Definition

PIN	SYMBOL	FUNCTION
1	Vss	Power Supply(GND)
2	Vdd	Power Supply(+5V)
3	Vo	Contrast Adjust
4	RS	Instruction/Data Register Select
5	R/W	Data Bus Line
6	E	Enable Signal
7-14	DB0-DB7	Data Bus Line
15	A	Power Supply for LED B/L(+)
16	K	Power Supply for LED B/L(-)

### 3.3 Power Supply For LCM Driving

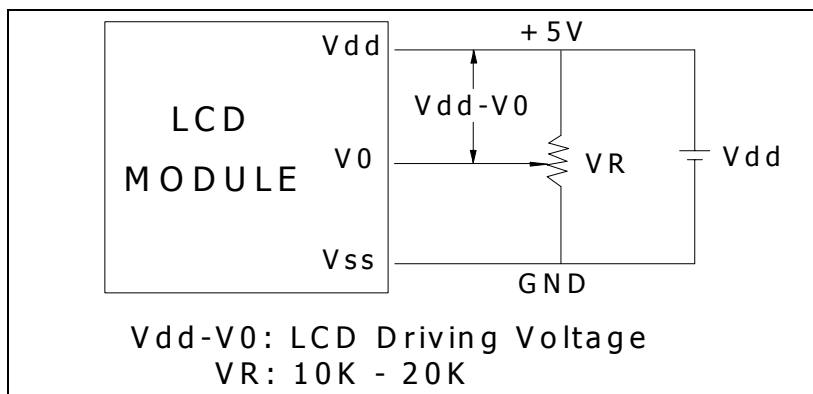

### 3.4 Display Character Address Code

POSITION	1	2	3	4	5	6	7	8	9	10	11	12	13	14	15	16
ADDRESS	00	01	02	03	04	05	06	07	40	41	42	43	44	45	46	47

\*NOTE: ALL OF THE NUMBERS ARE IN HEX FORMAT

## 4. ABSOLUTE MAXIMUM RATINGS

### 4.1 Electrical Absolute Maximum Ratings

ITEM	SYMBOL	CONDITION	MIN	MAX	UNIT
Supply Voltage (Logic)	Vdd – Vss	-	0	7.0	V
Supply Voltage (LCD Drive)	Vdd – V0	-	0	13.0	V
Input Voltage	Vi	-	-0.3	Vdd +0.3	V

### 4.2 Environmental Absolute Maximum Ratings

ITEM	SYMBOL	CONDITIONS	MIN	MAX	UNIT
Operating Temp	Topr	-Normal temp.	0	50	deg C
Storage Temp	Ttsg	version-	-20	70	deg C
Operating Temp	Topr	Extended temp.	-20	70	deg C
Storage Temp	Ttsg	version	-30	80	deg C
Humidity Endurance	RH	no ondensation Ta<=40 deg	-	95	%
Vibration	-	100-300Hz, X/Y/Z directions, 1 hour	-	4.9m/ss 0.5g	-
Shock	-	10 mS X/Y/Z direction 1 time each	-	29.4m/ss 3.0g	-

## 5. ELECTRICAL CHARACTERISTICS

### 5.1 DC Characteristics

Electrical Characteristics at Ta=25 deg C, Vdd = 5V + / - 5%

ITEM	SYMBOL	CONDITION	MIN	TYP	MAX	UNIT
Supply Voltage	Vdd-Vss	-	4.5	5.0	5.5	V

(logic)						
Supply Voltage (LCD)	Vdd-V0	Vdd = 5V	4.5	4.8	5.1	V
Input signal Voltage (for E, DB0-7,R/W,RS)	V-ih	"H" level	2.2	-	Vdd	V
	V-il	"L" level	0	-	0.6	V
Supply Current (logic)	Icc	-	-	1	1.2	mA
Supply Current (LCD)	Io	-	0.15	0.22	0.27	mA

## 5.2 AC Characteristics

TIMING SPECIFICATIONS at Ta = 25 deg C, Vdd = 5V+/-10%, Vss =0V

For Write mode

ITEM	SYMBOL	MIN	MAX	UNIT
E cycle time	tc	500	-	ns
E rise time	tR	-	25	ns
E fall time	tF	-	25	ns
E-pulse width (H, L)	tw	220	-	ns
R/W and RS set-up time	tsul	40	-	ns
R/W and RS hold time	tH1	10	-	ns
Data set-up time	tsu2	60	-	ns
Data hold time	tH2	10	-	ns

For Read mode

ITEM	SYMBOL	MIN	MAX	UNIT
E cycle time	tc	500	-	ns
E rise time	tR	-	25	ns
E fall time	tF	-	25	ns
E-pulse width (H, L)	tw	220	-	ns
R/W and RS set-up time	tsu	40	-	ns

R/W and RS hold time	tH	10	-	ns
Data output delay	tD	-	120	ns
Data hold time	tDH	20	-	ns

### WRITE MODE TIMING DIAGRAM

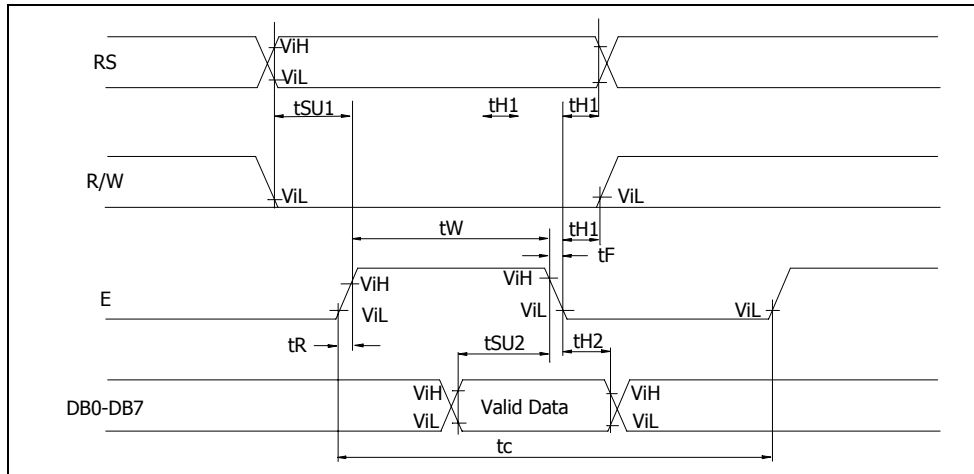

### READ MODE TIMING DIAGRAM

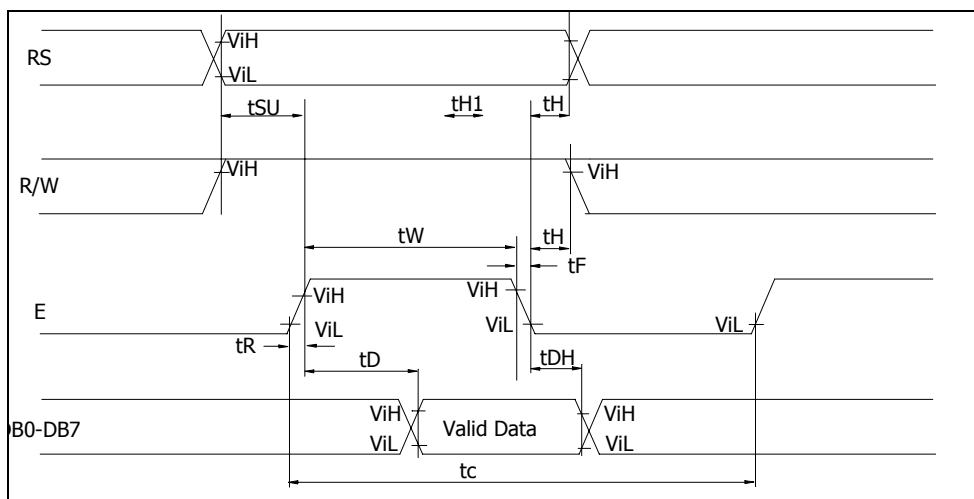

## 6. BACKLIGHT CHARACTERISTICS

### 6.1 Absolute Maximum Ratings

ITEM	SYMBOL	CONDITION	MIN	MAX	UNIT
Forward Current	Ifm	-	-	140	mA
Reverse Voltage	Vr	-	-	8	V
Power Dissipation	Pd	-	-	600	mW

### 6.2 Operating Parameters

ITEM	SYMBOL	CONDITION	MIN	TYP.	MAX	UNIT
Forward Voltage	Vf	If=100mA-	4.0-	4.2	4.4	V
Peak Wavelength	$\lambda$	If=100mA-	-	568	-	nm

## 7. ELECTRO-OPTICAL CHARACTERISTICS

(S) FOR STN TYPE, (T) FOR TN TYPE

ITEM	SYMBOL	CONDITION	MIN.	TYP.	MAX.	UNIT	REF.
Contrast	CR	25°C	--	12(S)/3(T)	--		Note1
Rise Time	tr	25°C	--	160	240	ms	Note2
Fall Time	tf	25°C	--	100	150	ms	note 2
Viewing Angle	$\theta 1$ - $\theta 2$	25°C	--	--	60(S)/20(T)	DEG	Note 3
	$\varnothing 1, \varnothing 2$		-40(S)/-15(T)	--	40(S)/15(T)		
Frame Frequency	Ff	25°C	--	70	--	Hz	note 2

Note(1): Contrast ratio is defined under the following condition:

CR=  $\frac{\text{brightness of selected condition}}{\text{brightness of non-selected condition}}$

- (a). Temperature-----25C
- (b). Frame Frequency-----64Hz
- (c). Viewing angle-----  $\theta = 0, \varnothing = 0$
- (d). Operating Voltage---5.0V

Note(2): definition of response time:

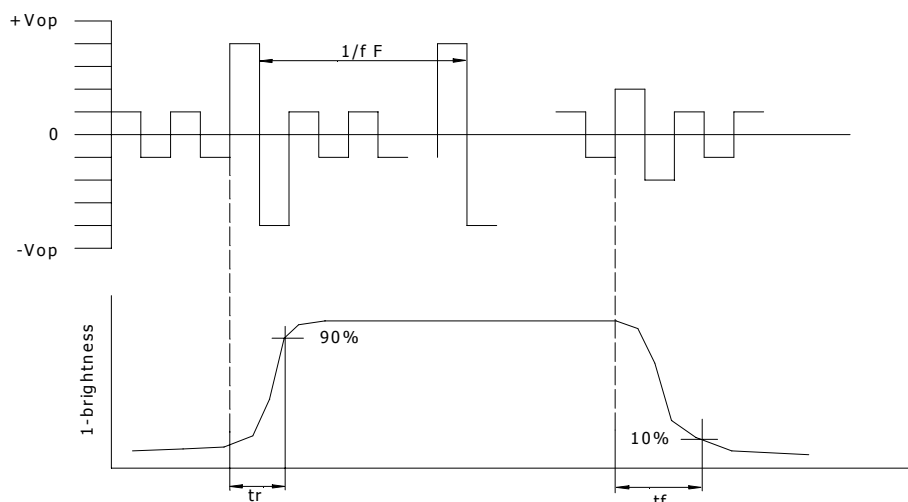

Condition:

- (a). Temperature-----25C
- (b). Frame Frequency-----64Hz
- (c). Viewing angle-----  $\theta = 0, \phi = 0$
- (d). Operating Voltage---5.0V

Note(3): definition of view angle:

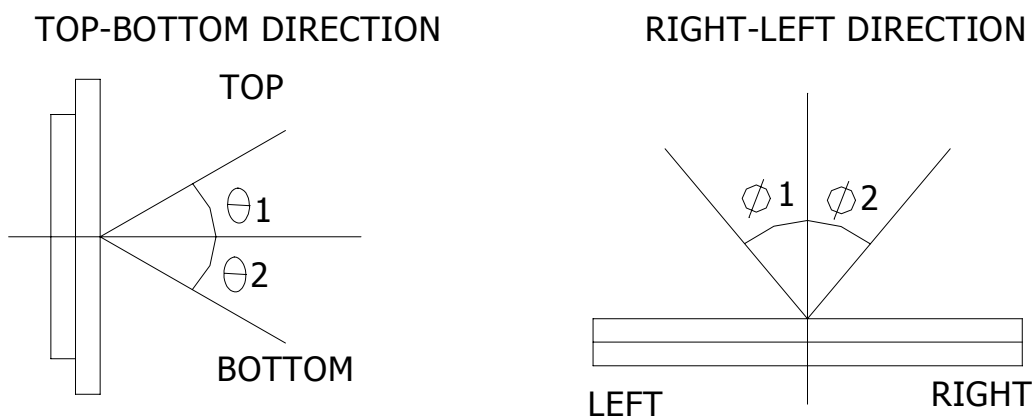

## 8. DISPLAY CONTROL INSTRUCTION

### 8.1 INSTRUCTION TABLE

Function	RR	SA	EE	EE	EE	EE	EE	EE	EE	Description	Execu Time* (Max)		
			7	6	5	4	3	2	1	0			
Clear Display	0	0	0	0	0	0	0	0	0	1	Clears entire display and returns the cursor to home position (address 0)	1.64mS	
Return Home	0	0	0	0	0	0	0	0	0	1	X	Return the cursor to the home position. DD RAM contents remain unchanged. Set DD RAM address to zero.	1.64mS
Entry mode set	0	0	0	0	0	0	0	0	1	1	S	Set cursor moving direction and enable the shift of the display. These operations are performed during data write/read of DD RAM/CG RAM. 1/D=1: increment; 1/D=0: decrement; S=1: whole display shift when data is written.	40 μ S
Display ON/OFF	0	0	0	0	0	0	1	D	C	B		Set display (D), cursor (C) and blinking of cursor (B) ON/OFF. D=1: display ON; D=0: display OFF.	40 μ S

control											C=1:Cursor ON; C=0:cursor OFF. B=1:Blink ON; B=0, Blink OFF.	
Cursor or Display shift	0	0	0	0	1	S	R	X	X		Move the cursor and shift the display without changing DDRAM contents. S/C=1: Display Shift; S/C=0:Cursor move. R/L=1:shift to right; R/L=0:shift to left.	40 $\mu$ S
Function Set	0	0	0	0	1	D	N	F	X	X	Set interface data length (DL), number of display lines (N) and character font (F).DL=1: 8 bits; DL=0: 4 bits. N=1: 2 lines; N=0: 1 lines. F=1: 5X11 dots; F=0: 5X7 dots.	40 $\mu$ S
Set CG RAM add	CG	0	0	0	1					ACG	Set CG RAM address. CG RAM data is sent and received after this setting.	40 $\mu$ S
Set DD RAM Add	DD	0	0	1						ADD	Set DD RAM address. DD RAM data is sent and received after this setting.	40 $\mu$ S
Read BF & Addr	BF	0	1	B						AC	Read BUSY FLAG (BF) and the contents of the address counter. BF=1: internal operation; BF=0: can accept instruction.	0 $\mu$ S
Write Data to RAM		1	0							WRITE DATA	Write data into DD RAM or CG RAM.	40 $\mu$ S**
Read Data from RAM		1	0							READ DATA	Read data from DD RAM or CG RAM.	40 $\mu$ S**

## 8.2 Character Table

POWER LIGHT

Upper 4 bit Lower 4 bit	LLLL	LLHH	LHLL	LHHL	HLHL	HLHL	HLHL	HLHL	HLHL	HLHL	HLHL	HLHL	HLHL	HLHL	HLHL	HLHL
LLLL				0	1	2	3	4	5	6	7	8	9	A	B	C
LLHH			!	1	Q	3	4			.	ア	イ	ウ	エ	オ	
LHLL			"	2	R	B	r			「	キ	ク	ケ	コ	カ	
LLHH			#	3	C	S	c			」	カ	キ	ク	ケ	コ	
LHLL			\$	4	D	T	d			、	エ	ト	チ	テ	ト	
LHLH			%	5	E	U	e			・	オ	カ	キ	ク	ケ	
LHHL			&	6	F	V	f			ヲ	カ	ニ	ヨ	ル	ル	
LHHH			'	7	G	W	g			ヲ	キ	ク	ケ	コ	カ	
HLLL			(	8	H	X	h			キ	ク	キ	リ	ル	ル	
HLLH			)	9	I	Y	i			カ	ク	ル	ル	ル	ル	
HLHL			*	:	J	Z	j			キ	コ	ク	ク	ク	ク	
HLHH			+	;	K	L	k			キ	ク	ク	ク	ク	ク	
HHLL			,	<	L	羊	l			カ	ク	ク	ク	ク	ク	
HHLH			-	=	M	I	m			ユ	ク	ク	ク	ク	ク	
HHHL			.	>	N	^	n			ヨ	ク	ク	ク	ク	ク	
HHHH			/	?	O	_	o			ウ	ク	ク	ク	ク	ク	

### 8.3 INITIALIZATION BY INSTRUCTION

POWER LIGHT

8-bits Power On      4-bits Power On

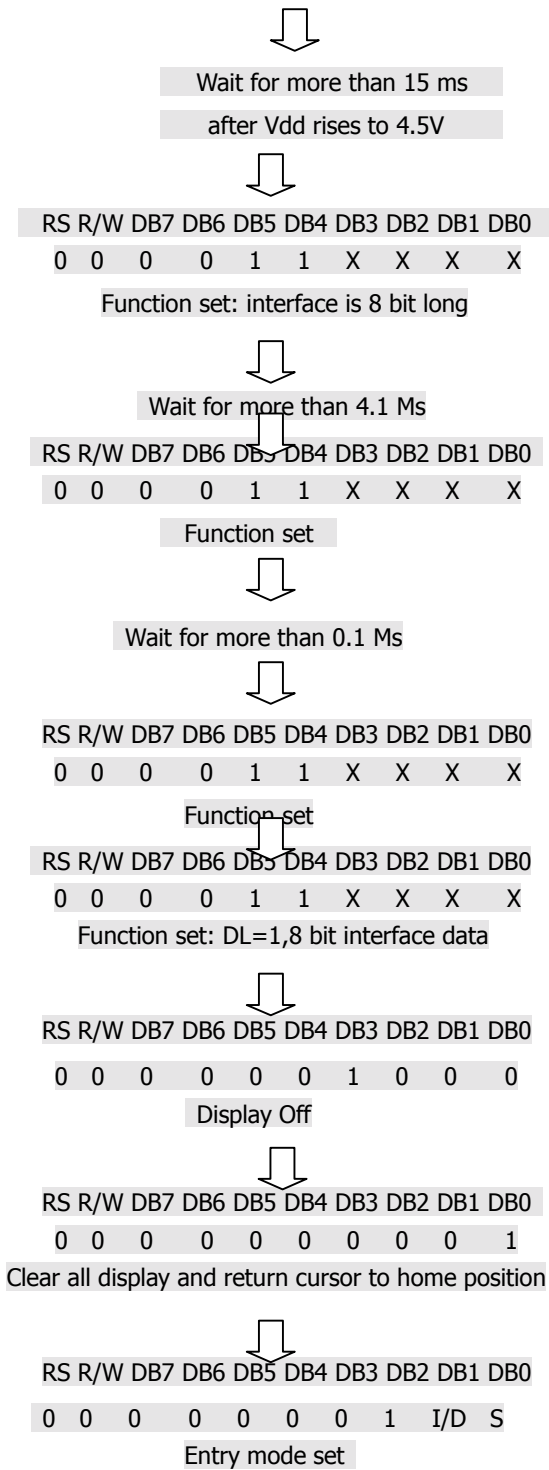

END OF INITIALIZATION

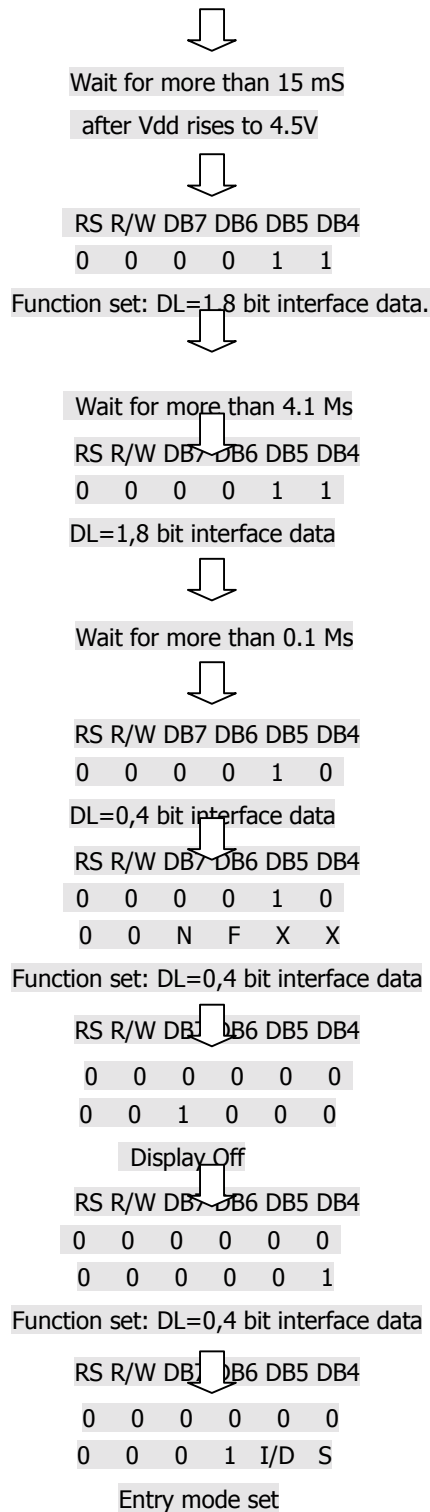

END OF INITIALIZATION

## 8.4 SOFTWARE EXAMPLES

### 8-BIT OPERATION 16 characters X 1 lines

Function	RS RW D7 D6 D5 D4 D3 D2 D1 D0	DISPLAY	DESCRIPTION
Power on delay		.....	Initialization. No display appears.
Function set	0 0 0 0 1 1 0 0 X X		Sets 8-bit operation, 2-line display and 5*7 dots character font.

Display OFF	0 0 0 0 0 0 1 0 0 0		Turn off display.
Display ON	0 0 0 0 0 0 1 1 1 0		Turn on display and cursor.
Entry Mode set	0 0 0 0 0 0 0 1 1 0		Set mode to increment the address by one and to shift the cursor to the right, at the time of write to the DD/CG RAM. Display is not shifted.
Write data to CG/DD RAM	1 0 0 1 0 0 1 1 1 0	N.....	Write "N". Cursor incremented by one and shift to right.
Write data to CG/DD RAM	1 0 0 1 0 0 0 1 0 1	NA.....	Write "A". Cursor incremented by one and shift to right
Write data to CG/DD RAM	. . . . .	NAM.....	Write "M" "E"
Set DDRAM address	0 0 1 1 0 0 0 0 0 0 0	NAME.....	Set RAM address so that the cursor is positioned at pos 8
Write data to CG/DD RAM	. . . . .	NAME.....TC	Write "T" "C".
Cursor or display shift	0 0 0 0 0 1 0 0 X X	NAME.....TC	Shift only the cursor position to the left.
Write data to CG/DD RAM	. . . . .	NAME TECH..	Write "E" "C" "H"

4-bit operation (4-bits 1 line)

Function	RS RW D7 D6 D5 D4	Display	Description
power on delay			Initialization. No display appears.
Frnction set	0 0 0 0 1 0		Sets to 4 -bit operation. In this case, operation is handled as 8-bits by initialization, and Only this instruction completes with one write.
Frnction set	0 0 0 0 1 0 0 0 0 0 X X		Sets 4 -bit operation, 1-line display and 5*7 dot character font. (number of display lines and character fontscannot be changed hence after.)
Display ON/OFF Control	0 0 0 0 0 0 0 0 1 1 1 0		Turn on display and cursor.
Entry Mode Set	0 0 0 0 0 0 0 0 0 1 1 0		Turn on display and cursor.
Write data to CG/DD/ARM	1 0 0 1 0 0 1 0 1 1 1 1		Write "O". Curaor incrementer by one and shift to right.
same as 8-bit operation			

9. INSPECTION STANDARDS

### 9.1 Inspection Conditions

The LCD shall be inspected under 40W white fluorescent light.  
 The distance between the eyes and the samples shall be more than 30cm.  
 All directions for inspecting the sample should be within 45 degree against perpendicular line.

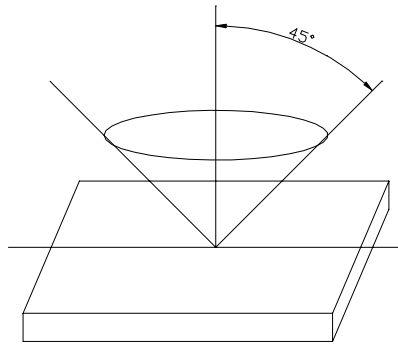

### 9.2 Definition of Applicable Zone

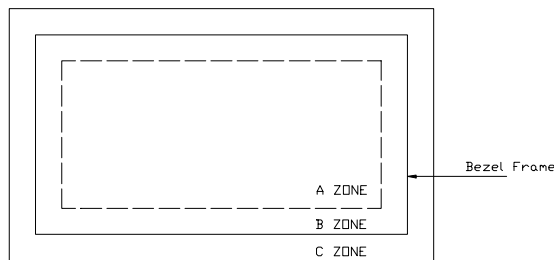

A Zone: Active Display Area  
 B Zone: Area from Bezel Frame to A Zone  
 C Zone: Rest Area of Bezel  
 A Zone + B Zone=Effective Viewing Area

### 9.3 Standards

NO	PARAMETER	CRITERIA			
1	Black and White Spots, Foreign Substances	Round Shape			
		Zone	Acceptable Number		
			A	B	C
		DIMENSION(MM)			
		$D \leq 0.1$	*	*	*
		$0.1 < D \leq 0.2$	5	5	*
$0.2 < D \leq 0.3$	0	1	*		
$0.3 < D$	0	0	*		
		D=(long+short)/2 * Disregard			

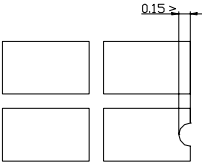
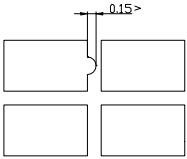
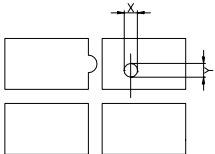
		<p><b>Line Shape</b></p> <table border="1"> <thead> <tr> <th colspan="2" rowspan="2">Zone</th> <th colspan="3">Acceptable Number</th> </tr> <tr> <th>A</th> <th>B</th> <th>C</th> </tr> </thead> <tbody> <tr> <td>X(mm)</td> <td>Y(mm)</td> <td></td> <td></td> <td></td> </tr> <tr> <td>-</td> <td><math>0.02 \geq W</math></td> <td>*</td> <td>*</td> <td>*</td> </tr> <tr> <td><math>2.0 \geq L</math></td> <td><math>0.03 \geq W</math></td> <td>3</td> <td>3</td> <td>*</td> </tr> <tr> <td><math>1.0 \geq L</math></td> <td><math>0.04 \geq W</math></td> <td>1</td> <td>2</td> <td>*</td> </tr> <tr> <td><math>1.0 \geq L</math></td> <td><math>0.05 \geq W</math></td> <td>0</td> <td>2</td> <td>*</td> </tr> <tr> <td>-</td> <td><math>0.05 &lt; W</math></td> <td colspan="3">Not acceptable</td> </tr> </tbody> </table> <p>X: Length Y: Width * Disregard Total defects shall not exceed 5.</p>	Zone		Acceptable Number			A	B	C	X(mm)	Y(mm)				-	$0.02 \geq W$	*	*	*	$2.0 \geq L$	$0.03 \geq W$	3	3	*	$1.0 \geq L$	$0.04 \geq W$	1	2	*	$1.0 \geq L$	$0.05 \geq W$	0	2	*	-	$0.05 < W$	Not acceptable		
Zone		Acceptable Number																																						
		A	B	C																																				
X(mm)	Y(mm)																																							
-	$0.02 \geq W$	*	*	*																																				
$2.0 \geq L$	$0.03 \geq W$	3	3	*																																				
$1.0 \geq L$	$0.04 \geq W$	1	2	*																																				
$1.0 \geq L$	$0.05 \geq W$	0	2	*																																				
-	$0.05 < W$	Not acceptable																																						
2	Air Bubbles (Between glass and polarizer)	<table border="1"> <thead> <tr> <th rowspan="2">Dimension(mm)</th> <th colspan="3">Acceptable Number</th> </tr> <tr> <th>A</th> <th>B</th> <th>C</th> </tr> </thead> <tbody> <tr> <td><math>D \leq 0.1</math></td> <td>*</td> <td>*</td> <td>*</td> </tr> <tr> <td><math>0.1 &lt; D \leq 0.2</math></td> <td>5</td> <td>5</td> <td>*</td> </tr> <tr> <td><math>0.2 &lt; D \leq 0.3</math></td> <td>0</td> <td>1</td> <td>*</td> </tr> <tr> <td><math>0.3 &lt; D</math></td> <td>0</td> <td>0</td> <td>*</td> </tr> </tbody> </table> <p>*: Disregard Total defects shall not exceed 3.</p>	Dimension(mm)	Acceptable Number			A	B	C	$D \leq 0.1$	*	*	*	$0.1 < D \leq 0.2$	5	5	*	$0.2 < D \leq 0.3$	0	1	*	$0.3 < D$	0	0	*															
Dimension(mm)	Acceptable Number																																							
	A	B	C																																					
$D \leq 0.1$	*	*	*																																					
$0.1 < D \leq 0.2$	5	5	*																																					
$0.2 < D \leq 0.3$	0	1	*																																					
$0.3 < D$	0	0	*																																					
3	The Shape of Dot	<p>(1) Dot Shape(with dent)</p>  <p>As per the sketch of left hand.</p> <p>(2) Dot Shape(with Projection)</p>  <p>Should not connect to next dot.</p> <p>(3) Pin Hole</p>  <p><math>(X+Y)/2 &lt; 0.2\text{mm}</math> (less than 0.1mm is not counted)</p> <p>Total defects shall not exceed 5.</p>																																						

4	Polarizer Scratches	Not to be conspicuous defects.
5	Polarizer Dirts	If the stains are removed easily from LCD surface, the module is not defective.
6	Color Variation	Not to be conspicuous defects.

## 10. PRECAUTIONS IN USING LCM

### 1. LIQUID CRYSTAL DISPLAY (LCD)

LCD is made up of glass, organic sealant, organic fluid, and polymer based polarizers. The following precautions should be taken when handling,

- (1). Keep the temperature within range of use and storage. Excessive temperature and humidity could cause polarization degradation, polarizer peel off or bubble.
- (2). Do not contact the exposed polarizers with anything harder than an HB pencil lead. To clean dust off the display surface. Wipe gently with cotton. Chamois or other soft material soaked in petroleum benzine.
- (3). Wipe off saliva or water drops immediately. Contact with water over a long period of time may cause polarizer deformation or color fading, while an active LCD with water condensation on its surface will cause corrosion of ITO electrodes.
- (4). Glass can be easily chipped or cracked from rough handling, especially at corners and edges.
- (5). Do not drive LCD with DC voltage.

### 2. Liquid Crystal Display Modules

#### 2.1 Mechanical Considerations

LCM are assembled and adjusted with a high degree of precision. Avoid excessive shocks and do not make any alterations or modifications. The following should be noted.

- (1). Do not tamper in any way with the tabs on the metal frame.
- (2). Do not modify the PCB by drilling extra holes, changing its outline, moving its components or modifying its pattern.
- (3). Do not touch the elastomer connector, especially insert a backlight panel (for example, EL).
- (4). When mounting a LCM make sure that the PCB is not under any stress such as bending or twisting. Elastomer contacts are very delicate and missing pixels could result from slight dislocation of any of the elements.
- (5). Avoid pressing on the metal bezel, otherwise the elastomer connector could be deformed and lose contact, resulting in missing pixels.

#### 2.2. Static Electricity

LCM contains CMOS LSI's and the same precaution for such devices should apply, namely

- (1). The operator should be grounded whenever he/she comes into contact with the module. Never touch any of the conductive parts such as the LSI pads, the copper leads on the PCB and the interface terminals with any parts of the human body.
- (2). The modules should be kept in antistatic bags or other containers resistant to static for storage.
- (3). Only properly grounded soldering irons should be used.
- (4). If an electric screwdriver is used, it should be well grounded and shielded from commutator sparks.
- (5). The normal static prevention measures should be observed for work clothes and working benches; for the latter a conductive (rubber) mat is recommended.
- (6). Since dry air is inductive to statics, a relative humidity of 50-60% is recommended.

#### 2.3. Soldering

- (1). Solder only to the I/O terminals.
- (2). Use only soldering irons with proper grounding and no leakage.
- (3). Soldering temperature:  $280\text{ }^{\circ}\text{C} \pm 10^{\circ}\text{C}$
- (4). Soldering time: 3 to 4 sec.
- (5). Use eutectic solder with resin flux fill.
- (6). If flux is used, the LCD surface should be covered to avoid flux spatters. Flux residue should be removed afterwards.

#### 2.4. Operation

- (1). The viewing angle can be adjusted by varying the LCD driving voltage  $V_0$ .
- (2). Driving voltage should be kept within specified range; excess voltage shortens display life.
- (3). Response time increases with decrease in temperature.
- (4). Display may turn black or dark blue at temperatures above its operational range; this is (however not pressing on the viewing area) may cause the segments to appear "fractured".
- (5). Mechanical disturbance during operation (such as pressing on the viewing area) may cause the segments to appear "fractured".

#### 2.5. Storage

If any fluid leaks out of a damaged glass cell, wash off any human part that comes into contact with soap and water. Never swallow the fluid. The toxicity is extremely low but caution should be exercised at all the time.

**END**

POWER LIGHT